

BEFCO®

Operator's Manual

CYCLONE

Three Spindle Grooming Mower

C70-090, C70-110

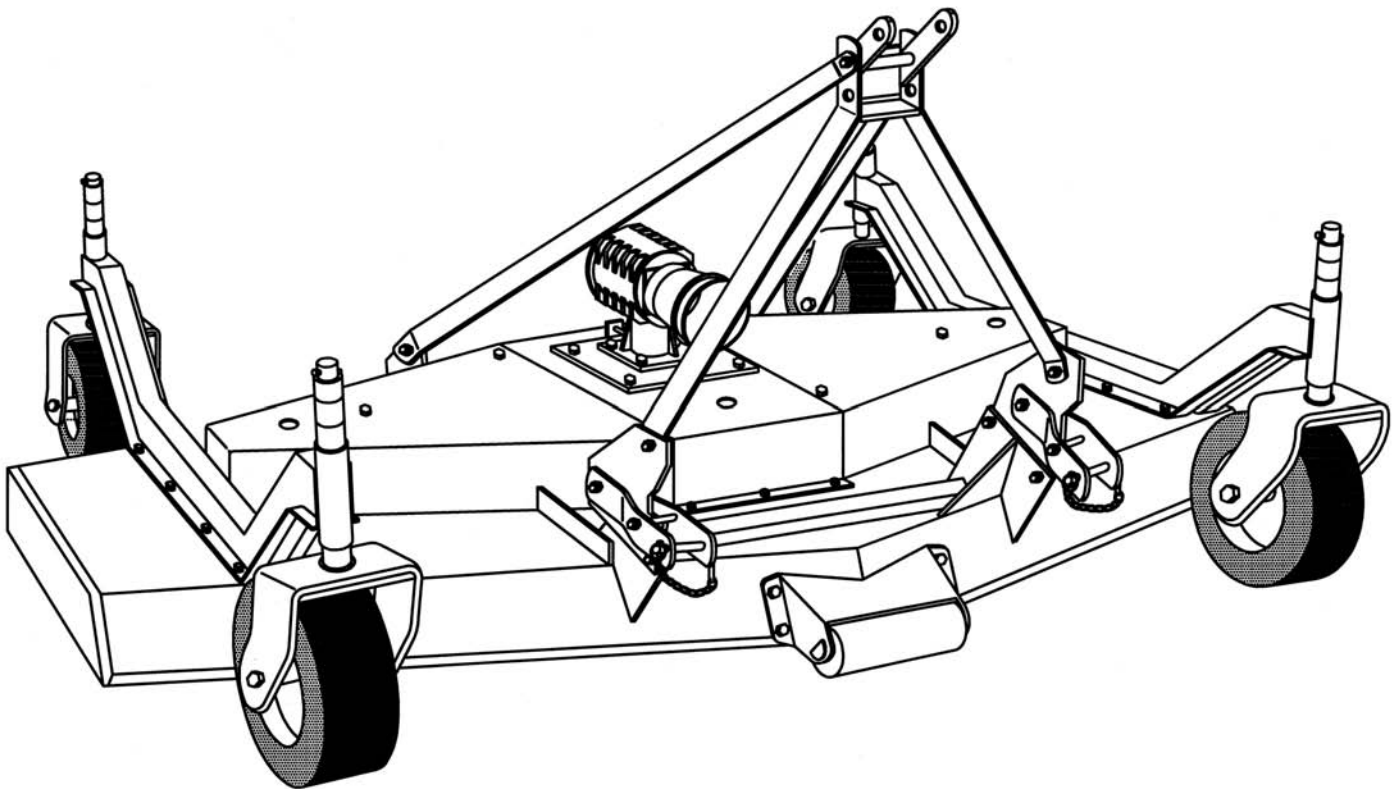

The operator's manual is a technical service guide and must always accompany the machine.

Manual 971-138B

August 2018

SAFETY

Take note! This safety alert symbol found throughout this manual is used to call your attention to instructions involving your personal safety and the safety of others. Failure to follow these instructions can result in injury or death.



*This symbol means:
ATTENTION!
BECOME ALERT!
YOUR SAFETY IS INVOLVED!*

Signal Words

Note the use of the signal words DANGER, WARNING and CAUTION with the safety messages. The appropriate signal words for each have been selected using the following guidelines:



DANGER: Indicates an imminently hazardous situation that, if not avoided, will result in death or serious injury.



WARNING: Indicates a potentially hazardous situation that, if not avoided, could result in death or serious injury, and includes hazards that are exposed when guards are removed. It may also be used to alert against unsafe practices.



CAUTION: Indicates a potentially hazardous situation that, if not avoided, may result in minor or moderate injury.

INDEX

1 - GENERAL INFORMATION	4
1.01 - General	4
1.02 - Warranty Information	4
1.03 - Model and Serial Number ID	5
2 - SAFETY PRECAUTIONS	6
2.01 - Preparation	6
2.02 - Starting and Stopping	7
2.03 - Messages and Signs	7
3 - OPERATION	10
3.01 - Operational Safety	10
3.02 - Set Up	12
3.03 - Cutting Height Adjustment	13
3.04 - Pre-Operational Check	14
3.05 - Attaching to the Tractor	14
3.06 - Start Up	15
3.07 - Working Speed	16
3.08 - Operating Techniques	17
3.09 - Uneven Terrain	18
3.10 - Removing Mower from the Tractor	18
3.11 - Quick Hitch Adapter Assembly and Operation	18
4 - MAINTENANCE	21
4.01 - Maintenance Safety	21
4.02 - Service	22
4.03 - Blade Maintenance	23
4.04 - Belt Tension	25
4.05 - Belt Replacement	26
4.06 - Driveline	27
4.07 - Transport	28
4.08 - Storage	29
5 - REPAIR PROCEDURES	31
5.01 - Gearbox	31
5.02 - Blade Spindle	31
5.03 - Suggested Spare Parts	33
6 - TROUBLESHOOTING	34
7 - PRE-DELIVERY CHECKLIST	36
8 - WARRANTY	37
PARTS MANUAL	41

1 - GENERAL INFORMATION

Thank you and congratulations for having chosen our implement. Your new grooming mower is a technologically advanced machine constructed of high quality, sturdy components that will fulfill your working expectations. Read this manual carefully. It will instruct you on how to operate and service your mower safely and correctly. Failure to do so could result in personal injury and/or in equipment damage.

1.01 - General

The implement described in this manual is to be used with tractors with PTO at 540 rpm and clockwise rotation.



CAUTION: Always ensure that the coupling of the implement with the tractor is done at the same PTO speed and direction of rotation. Do not operate this implement at a PTO speed or direction of rotation other than that shown on the implement. Serious damage can occur to the machine and/or the operator.



CAUTION: Unless otherwise specified, all hardware is metric. Use only metric tools on metric hardware. Other tools that do not fit properly can slip and cause injury.



CAUTION: Right hand and left hand sides of the implement are determined by facing in the direction the implement will travel when going forward (see fig. 2).

1.02 - Warranty Information

Carefully read the Warranty section¹, detailing coverage and limitations of this warranty. **Warranty** is provided for customers who operate and maintain their equipment as described in this manual. Warranty registration is accomplished by the dealer by completing and forwarding the **Warranty Registration** form to the Company, along with a copy of the dealer's invoice. It is in your best interest to insure that this has been done.

Warranty does not cover the following:

1. Cleaning, transporting, mailing and service call charges.

¹ See Chapter 8 - Warranty.

2. Normal wear items such as belts, blades, bearings, drivelines, shear pins, slip clutches, etc.
3. Depreciation or damage caused by normal wear, accidents, improper maintenance, improper protection or improper use.
4. The use of non-original spare parts and accessories.

Your Authorized Company Dealer has genuine parts in stock. Only these approved replacement parts should be used.

This limited warranty covers defective material and workmanship. The cost of normal maintenance or repairs for accidents or improper use and related labor will be borne by the owner.

1.03 - Model and Serial Number ID

Attached to the frame is an ID plate showing the model and the serial number. Record your implement model and serial number in the space provided below. Your dealer needs this information to give you prompt, efficient service when you order parts.

BEFCO	1781 S. Wesleyan Blvd. — P.O. Box 6036 Rocky Mount, N.C. 27802 — U.S.A. Tel: 1.252.977.9920 Fax: 1.252.977.9718
MODEL:	<input type="text"/>
SERIAL:	<input type="text"/>
VERSION:	<input type="text"/>

2 - SAFETY PRECAUTIONS

Safety is the primary concern in the design and manufacture of our products. Unfortunately our efforts to provide safe equipment can be wiped out by a single careless act of an operator.

In addition to the design and configuration of equipment, hazard control and accident prevention are dependent upon the awareness, concern, prudence and proper training of personnel involved in the operation, transport, maintenance and storage of equipment. It is the operator's responsibility to read and understand all safety and operating instructions in the manual and to follow these.

Allow only properly trained personnel to operate the mower. Working with unfamiliar equipment can lead to careless injuries. Read this manual, and the manual for your tractor, before assembly or operation, to acquaint yourself with the machines. It is the mower owner's responsibility, if this machine is used by any person other than yourself, is loaned or rented, to make certain that the operator, prior to operating, reads and understands the operator's manuals and is instructed in safe and proper use.

2.01 - Preparation



1. Before operating equipment read and understand the operator's manual and the safety signs (**see fig. 2**).
2. Thoroughly inspect the implement before initial operation to assure that all packaging materials, i.e. wires, bands, and tape have been removed.
3. Personal protection equipment including hard hat, safety glasses, safety shoes, and gloves are recommended during assembly, installation, operation, adjustment, maintaining and/or repairing the implement.
4. Operate the mower only with a tractor equipped with an approved Roll-Over-Protective-System (ROPS). Always wear your seat belt. Serious injury or even death could result from falling off the tractor.
5. Clear area to be cut of stones, branches or other debris that might be thrown, causing injury or damage.
6. Operate only in daylight or good artificial light.
7. Ensure mower is properly mounted, adjusted and in good operating condition.
8. Ensure that all safety shielding and safety signs are properly installed and in good condition.

2.02 - Starting and Stopping



1. Be sure that no one is near the machine prior to engaging or while the machine is working.
2. Be sure the tractor is in "Neutral" before starting engine.
3. Mower operating power is supplied from tractor PTO. Refer to your tractor manual for PTO engagement and disengagement instructions. Always operate PTO at 540 rpm. Know how to stop the tractor and mower quickly in case of an emergency.
4. When engaging PTO, the engine rpm should always be low. Once engaged and ready to start cutting, raise PTO speed to 540 rpm and maintain throughout cutting operation.
5. Check the tractor master shield over the PTO stub shaft. Make sure it is in good condition and fastened securely to the tractor. Purchase a new shield if old shield is damaged or missing.
6. After striking an obstacle, disengage the PTO, shut the tractor down and thoroughly inspect for damage before restarting.
7. Never engage the PTO until the mower is in the down position and resting on the ground. Never raise the mower until all blades have come to a complete stop.
8. To park the vehicle safely, stop vehicle on a level surface (not on a slope), disengage PTO, engage the parking brake, stop the engine, remove the key, and wait for engine and all moving parts to stop before leaving the operator's seat.
9. Stay clear of rotating drivelines. Entanglement in rotating driveline can cause serious injury or death. Wear close fitting clothing. Stop the engine and be sure PTO driveline is stopped before getting near it.

2.03 - Messages and Signs



1. Read and adhere to all safety and operating decals on this machine (**see fig. 2**).
2. Before dismounting tractor: Allow moving parts to stop, stop engine, set brake and remove the key of unattended equipment.
3. Keep away from rotating blades and driveline.
4. Keep guards and shields in place and in good condition.
5. Do not mow with bystanders in area.
6. Allow no riders on tractor or mower.
7. Allow moving parts to stop before repair.
8. Securely support mower before working underneath.

Additional warning and operating decals are available at no extra charge. Please specify model and serial number when ordering.

Fig. 2 - Safety decals - implement; replace immediately if damaged.

Safety decals - driveline; replace immediately if damaged.

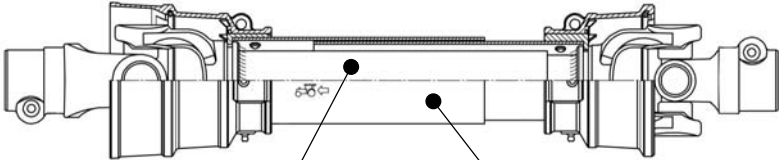

placed on outer tube



placed on outer shield

3 - OPERATION

You have purchased a three spindle mower designed especially for the mowing of grassy areas where a highly professional cut is required without wasting time.

This mower is perfect for the maintenance of parks, private lawns, industrial parks, airports, hospital grounds, schools, highways, golf courses, sport complexes, etc. The C70 series, for tractors up to 70 HP, come in working widths of 90" and 110". The mower can be either tractor front or rear mounted. On your mower, the tractor PTO transmits its power through a driveline to a speed multiplier gearbox. A pulley is attached to the pinion gear shaft of the gearbox which, via high resistance belts, transmits power to pulleys coupled to the three individual spindle shafts. Blades are secured to these shafts which turn at a high blade tip speed to cut the grass.

Our C70 grooming mower comes equipped with 4 swivel wheels. Aside from regulating the cutting height, the wheels are set in such a way as to allow the mower to follow the contour of the terrain and give a precise, level cut even in undulating conditions.

3.01 - Operational Safety



CAUTION: Our mowers are designed considering safety as the most important aspect and are the safest available in today's market. Unfortunately, human carelessness can override the safety features built into our machines. Injury prevention and work safety, aside from the features on our mowers, are very much due to the responsible use of the equipment. It must always be operated prudently following with great care, the safety instructions laid out in this manual.



1. The use of this equipment is subject to certain hazards which cannot be prevented by mechanical means or product design. All operators of this equipment must read and understand this entire manual, paying particular attention to safety and operating instructions, prior to using.
2. Do not operate the tractor and mower when you are tired, sick or when using medication.
3. Keep all helpers and bystanders at least 300 feet from a rotary mower. Only properly trained people should operate this machine.
4. When this machine is operated in populated areas where thrown objects could injure persons or property, standard equipment safety chain shielding (which is designed to reduce the possibility of thrown objects) must be installed.
5. The majority of accidents involve entanglements on the driveline, injury of bystanders by objects thrown by the rotating blades, and operators being knocked off the tractor by low hanging limbs and then being run over by the mower. Accidents

- are most likely to occur with machines that are loaned or rented to someone who has not read the operator's manual and is not familiar with a rotary mower.
6. Always stop the tractor, set brake, shut off the tractor engine, remove the ignition key, lower implement to the ground and allow mower blades to come to a complete stop before dismounting tractor. Never leave equipment unattended with the tractor running.
 7. Never place hands or feet under mower with tractor engine running or before you are sure all motion has stopped. Stay clear of all moving parts.
 8. Do not allow riders on the mower or tractor at any time. There is no safe place for riders.
 9. Do not operate unless all personnel, livestock and pets are at least 300 feet away to prevent injury by thrown objects.
 10. Before backing up, disengage the mower and look behind carefully.
 11. Install and secure all guards and shields before starting or operating.
 12. Keep hands, feet, hair and clothing away from moving parts.
 13. This rotary mower is designed for use only on tractors with 540 rpm power take off.
 14. Never operate tractor and mower under trees with low hanging limbs. Operators can be knocked off the tractor and then run over by the rotating blades.
 15. The rotating parts of this machine have been designed and tested for rugged use. However, they could fail upon impact with heavy, solid objects such as steel guard rails and concrete abutments. Such impact could cause the broken objects to be thrown outward at very high velocities. To reduce the possibility of property damage, serious injury, or even death, never allow the cutting blades to contact such obstacles.
 16. Frequently check mower blades. They should be sharp, free of nicks and cracks and securely fastened.
 17. Stop mower immediately upon striking an obstruction. Turn engine off, remove key, inspect and repair any damage before resuming operation.
 18. Stay alert for holes, rocks and roots in the terrain and other hidden hazards. Keep away from drop-offs.
 19. Use extreme care and maintain minimum ground speed when transporting on hillside, over rough ground and when operating close to ditches or fences. Be careful when turning sharp corners.
 20. Reduce speed on slopes and sharp turns to minimize tipping or loss of control. Be careful when changing directions on slopes. Do not start or stop suddenly on slopes. Avoid operation on steep slopes.
 21. When using a unit, a minimum 20% of tractor and equipment weight must be on tractor front wheels. Without this weight, tractor could tip over, causing personal injury or death. The weight may be attained with a front end loader, front wheel weights, ballast in tires or front tractor weights. When attaining a minimum 20% of tractor and equipment weight on the front wheels, you must not exceed the ROPS weight certification. Weigh the tractor and equipment. Do not guess or estimate!
 22. Inspect the entire machine periodically². Look for loose fasteners, worn or broken parts, and leaky or loose fittings.

² See Chapter 4 - Maintenance.

23. Use only the driveline supplied with the mower. Do not use it if it is missing any shield or safety protection.
24. Pass diagonally through sharp dips and avoid sharp drops to prevent "hanging up" tractor and mower.
25. Avoid sudden starts and stops while traveling up or downhill.
26. Always cut down slopes; never across the face. Avoid operation on steep slopes. Slow down on sharp turns and slopes to prevent tipping and/or loss of control.

3.02 - Set Up

Notice to dealer: Pre-delivery setup and service including lubrication is the responsibility of the authorized dealer. It is up to him to assure that the machine is in perfect condition and ready to be used. It is his responsibility to ensure that the customer is aware of all safety aspects and operational procedures for the mower. He must also fill out the Pre-Delivery Checklist³ prior to delivering the mower.

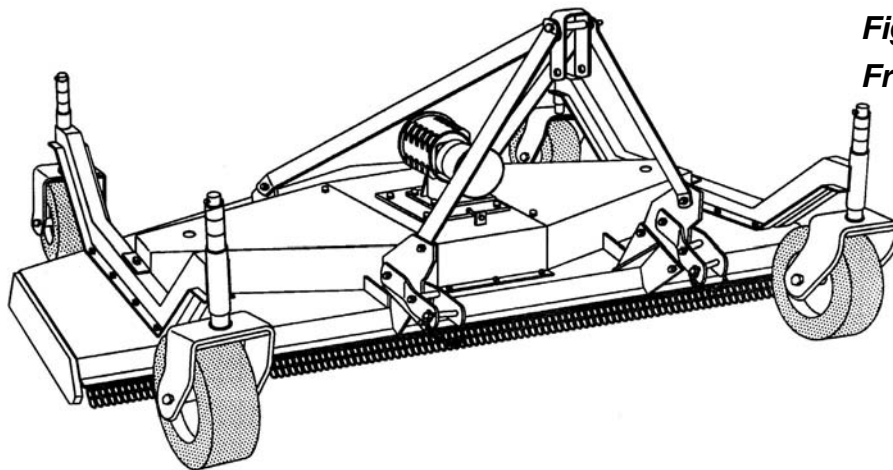
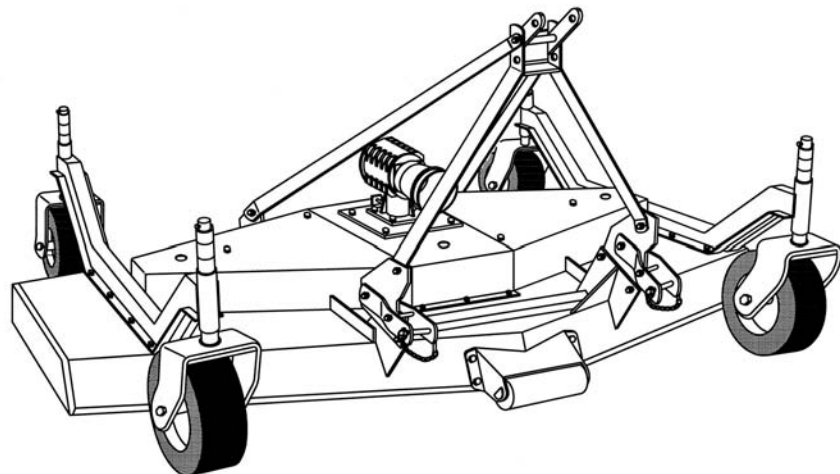

Fig. 3
Front mounted mower.

Fig. 4
Rear mounted mower.



³ See Chapter 7 - Pre-Delivery Checklist.



CAUTION: Stand clear of bands when cutting as they could be under sufficient tension to cause them to fly loose. Take care in removing bands and wire, they often have extremely sharp edges and cut very easily.

As mentioned above, all our grooming mowers may be either tractor front or rear mounted. Changing our mowers from front mount to rear, or vice versa, can be easily done at our authorized dealerships. This is accomplished by simply turning the three point hitch and the gearbox 180 degrees (see fig. 3 & 4).

3.03 - Cutting Height Adjustment



WARNING: Keep hands and feet away from moving blades. Be sure tractor engine is off, parking brake is locked, and key is removed before making any adjustments. Never rely on the tractor lift system. Install blocks or stands under the mower deck to prevent it from falling.

Fig. 5
The cutting height is adjusted by moving the height adjustment spacers on the wheel yokes above or below the wheel arm.

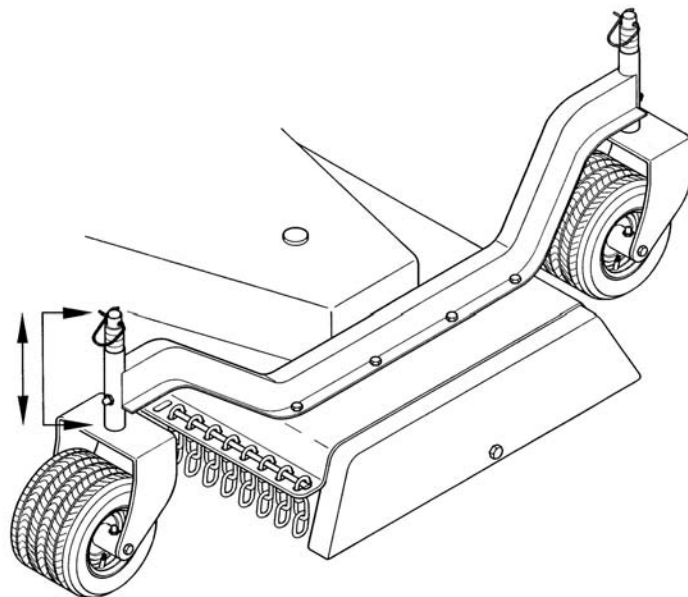

The cutting height is the distance from the blades to the ground. The cutting height is adjusted by **moving the spacers on the wheel yokes**. Placing spacers between the wheel arm and the wheel yoke raises the cutting height by the size of the spacer. Removing the spacers lowers it by the same height (see fig. 5).

Be sure all wheel arms are adjusted equally. This is the only way to ensure a completely uniform cut.

IMPORTANT: Very low cutting heights should be avoided. Damaging shock loads occur when the blades strike the ground repeatedly. This can cause damage to the mower.

Cutting lower than 2" under most circumstances should be avoided.

The cutting height is adjustable from 1.3" to 5.3".

The mower comes equipped with a front anti-scalping roller. The roller is particularly helpful when cutting over uneven terrain.

3.04 - Pre-Operational Check

IMPORTANT: Check each of the following, carefully, prior to engaging the equipment:

1. The spindle bearings have been greased.
2. The belts for proper tension.
3. The oil level in gearbox. Using a flashlight, check inside the gearbox to verify that it's approximately half full.
4. The driveline cross and bearings have been greased.
5. No wrappings or foreign objects are around the blades, belts or driveline.
6. The blades are properly installed and the blade bolts properly torqued⁴.
7. All hardware is tight.
8. The tractor, to ensure correct direction of PTO and rpm speed.
9. All safety shields and guards are in place and tightly attached.
10. No people or animals are in the work area.
11. When working, make sure the tractor hitch is in the "float" position, in order to allow the mower to follow the contour of the ground.



DANGER: Stay clear of rotating driveline. Entanglement in rotating driveline can cause serious injury. Disengage PTO, engage parking brake or place transmission in "Park", shut off the tractor and remove the key before working around hitch, attaching or detaching driveline, making adjustments, servicing or cleaning the machine.

3.05 - Attaching to the Tractor

Unit may be used on tractors ranging from 30 to 70 HP equipped with a standard PTO and category 1 three point hitch⁵. **Never use this mower with tractors over 70 HP.**



CAUTION: Check the tractor PTO rpm to ensure it is set at 540 and turns clockwise.

⁴ See Table 1, page 30.

⁵ See Table 2, page 30.



CAUTION: Always ensure that the tractor tire pressure is correct according to the tractor operator's manual.



DANGER: Failure to ensure a secure coupling of the implement to the tractor can cause injury and damage to the implement or tractor.

To attach the mower to the tractor do the following:

1. Back the tractor up to the mower in order to slip the tractor hitch arms over the hitch pins welded to the mower hitch arms. **Turn off the tractor engine.** Secure them in place with the lynch pins.
2. Adjust the tractor sway blocks or chains to remove all side movement.
3. Attach the top link. Adjust tractor top link to allow the mower to follow the ground contour and yet remain as level as possible when raised to transport position.
4. Install the shielded driveline to the tractor by first lining up the splines and depressing the snap pin. Push the yoke onto the PTO shaft as far as it will go. Release the pin and pull back slowly until the pin clicks in place. Repeat this operation on the implement end.
5. Ensure that the driveline has at least 2" from bottoming out in its shortest working position and has the minimum 6" overlap in its longest working position. Refer to **Section 4.06⁶** of this manual, if it is determined that the driveline is too long and needs to be shortened. Contact your local dealer if it is determined that the driveline is too short for your tractor.
6. Attach the driveline chains to the tractor and to the mower to keep the driveline protection from turning. The chains should not be too tight.

3.06 - Start Up



DANGER: The mower must always be lowered to the ground before starting tractor engine or engaging PTO lever.

Lower mower to the ground with the tractor rock shaft control lever. With the engine idling, slowly engage the PTO drive. Move the throttle lever until the PTO speed indicated on the mower is obtained.

The mower is set for a PTO speed of 540 rpm.

Shift the transmission to a slow speed gear and start forward, increase the ground speed by shifting upward until the desired speed is obtained. Do not mow in reverse unless absolutely necessary and only after careful observation of the area behind the mower.

⁶ See Section 4.06 - Driveline, for instructions on how to determine correct driveline length and procedures for shortening the driveline.



CAUTION: Do not operate this mower at a PTO speed or direction of rotation other than that shown on the mower. Serious damage can occur to the machine and/or the operator.

Before starting to mow, never forget that the **operator is responsible** for the following:

1. Safe and correct driving of the tractor and mower.
2. To learn precise safe operating procedures for both the tractor and the mower.
3. To ensure all maintenance and lubrication has been performed on the mower.
4. To have read and understood all safety aspects for the mower in the operator's manual.
5. To have read and understood all safety decals on the mower.
6. Checking the condition of the blades. Worn or damaged blades should be changed before starting⁷.
7. Checking to ensure that the cutting edge is the leading edge of the blade⁸.
8. Checking that there is no wire, weed, grass or other material wrapped around blades.
9. Checking to see if front weights need to be added to the tractor in order to maintain balance.
10. Checking the tractor tires for the proper pressure in accordance with the tractor operator's manual.
- 11. Checking that the PTO shield, belt shields and all other shielding are on the machine and securely in place.**
12. Making sure the proper attire is worn. Avoiding loose fitting clothing which can become entangled. Wearing sturdy, tough-soled work shoes and protective equipment for eyes, hands, ears and head. Never operate tractor or implements in bare feet, sandals or sneakers.
13. Checking area for stones, branches and other debris that might be thrown.
14. Ensuring proper lighting is available, sunlight or good artificial lighting.

3.07 - Working Speed

The mowing speed depends on ground conditions, tractor HP, mowing height, and grass thickness. Only a test run will enable you to gauge the optimal working speed for your conditions. Under most conditions a 3 to 8 mph ground speed is best. As a rule of thumb, and if the conditions permit, grass dispersion is increased by higher ground speeds.

In order to obtain the best cut possible, always keep the tractor rpm up to the speed indicated on the mower. When increasing or decreasing mowing ground speed, always use gear selection, not engine speed. This will maintain the constant maximum blade speed necessary for a clean cut.

⁷ See Section 4.03 - Blade Maintenance.

⁸ See Section 4.03 - Blade Maintenance.

3.08 - Operating Techniques

All of the following factors are important in selecting the proper forward speed:

1. Height of grass.
2. Type of grass.
3. Density of grass.
4. Type of terrain.
5. Grass condition, wet or dry.

This mower has been designed to cut grass with heights from 4" to 8". It is recommended to avoid cutting grass taller than 10". For the best results, try cutting the grass at least once per week during growing season. Tall, dense grass should be cut at low speed, while thin medium grass can be cut at a faster ground speed. For cleaner cuts and efficient mowing, the blades must be kept sharp⁹.

Always operate PTO at 540 rpm. This is necessary to maintain proper blade speed and obtain a clean cut.

Under certain conditions, tractor tires may roll some grass down and prevent it from being cut at the same height as the surrounding area. If this occurs reduce the tractor ground speed but maintain a 540 rpm engine speed. The lower ground speed will permit the grass to at least partially rebound. Under some conditions grass will not rebound enough to be cut evenly, resulting in an uneven appearance. In general, lower cutting height gives a more even cut with less tendency to leave tire tracks. If cut is still not satisfactory, cut the area twice.

Mow extremely tall grass twice. On the first pass use a high cutting height. On the second pass position the mower at the desired height and, when practical, mow at a right angle in travel to the first pass.

Plan your pattern to travel straight forward whenever possible. It is better to cut grass more often, than too short. Short grass deteriorates rapidly in hot weather and invites weed growth during growing season.

If at any time the mower should jam resulting in belt slippage of 2 or more seconds, raise the mower and continue for 2-3 minutes. This will allow the pulleys to cool and prolong belt life.



DANGER: The mower blades can throw objects hundreds of feet which could result in personal or property damage.

Pick up all rocks and other debris before mowing.

Enter new areas carefully. Cut grass higher at first, allowing mower to clear hidden objects.



CAUTION: For emergency reasons learn how to stop the tractor and mower quickly. On the finishing mowers always disengage the PTO, lock parking brake,

⁹ See Sharpening Blades in Section 4.03 - Blade Maintenance.

stop engine and allow the mower blades to come to a complete stop before dismounting the tractor.

3.09 - Uneven Terrain



DANGER: Be careful of rollover when operating tractor and mower over uneven ground.

The following precautions should always be observed when working on uneven terrain:

1. In extremely uneven terrain rear wheel weights, front tractor weights, and/or tire ballast should be used to improve stability.
2. Observe the type of terrain and develop a safe working pattern.
3. Whenever traction or stability is doubtful, first test drive over the terrain with the PTO disengaged.
4. Operate the implement up and down steep slopes, not across slopes, to prevent the tractor from tipping. Avoid sudden stops and starts, and slow down before changing directions on a slope.
5. Pass diagonally through sharp dips and avoid sharp drops to prevent hanging up the tractor and implement.
6. Slow down on sharp turns and slopes to prevent tipping or loss of control.
7. Avoid tipping the mower while cutting.
8. Watch for holes, roots or other hidden objects. Do not use near the edge of a gully, ditch or stream bank.

An anti-scalping roller is mounted on the deck for uneven ground contours. The roller rides the nose of the mower over a mound to help keep the nose from bulldozing or the blade from scalping the ground.

3.10 - Removing Mower from the Tractor



CAUTION: Disengage tractor PTO. Set parking brake. Stop engine and remove key from ignition. Disconnect mower driveline from tractor PTO shaft. Collapse driveline and store in appropriate place. Disconnect three point linkage and carefully drive tractor away from mower.

3.11 - Quick Hitch Adapter Assembly and Operation

Using a Quick Hitch system: The C70 series mowers can be used with a Quick Hitch system, allowing for quick and easy hookup, by installing an optional adapter. This

optional adapter has floating yokes that will allow the mower to follow the contour of the ground.



WARNING: When using a Quick Hitch on a PTO driven implement always ensure there is the proper driveline overlap prior to use. If there is not the minimum 6” driveline overlap do not use and contact your nearest dealer to purchase a longer driveline.

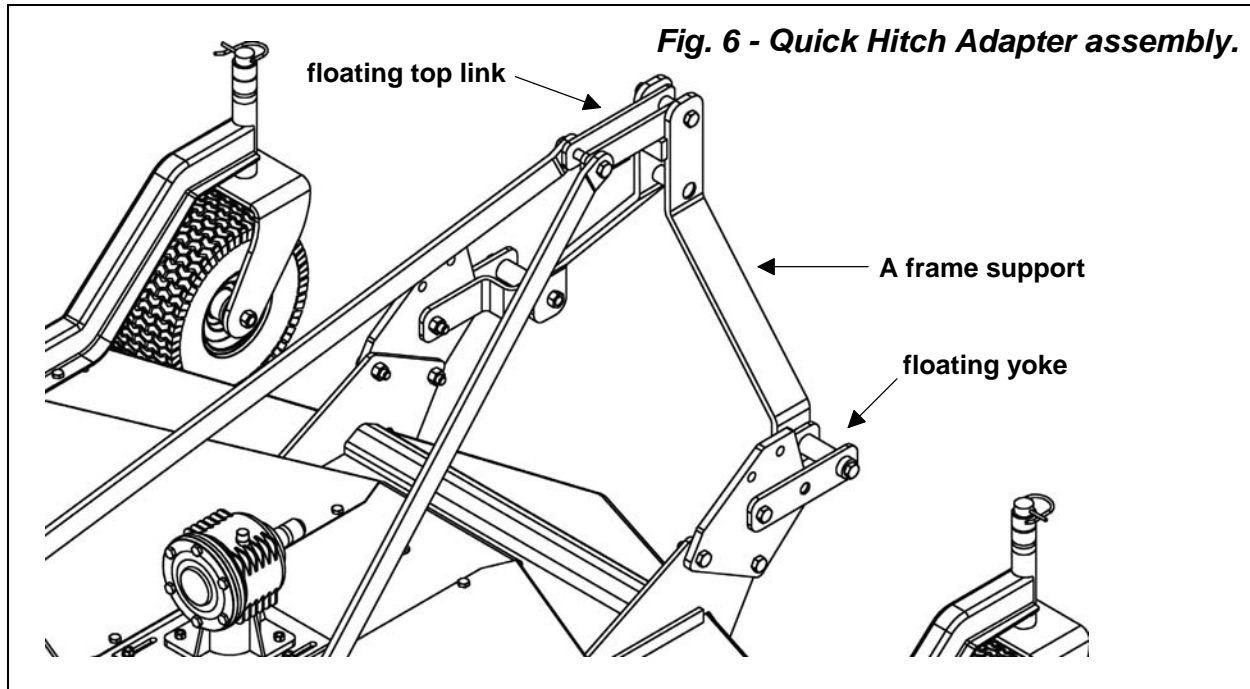

Quick Hitch Adapter assembly (see fig. 6):

1. Remove lower hitch arms from grooming mower's linking plates.
2. Remove the M16x150 bolt on top of the three point hitch of the grooming mower.
3. Remove the M16x45 bolts that hold the top hitch supports to the linking plates of the mower.
4. Install the floating yokes of Quick Hitch Adapter assembly to the linking plates of the mower using the M16x65 bolts and the M16 nuts. Install the floating yokes in the same hole that the hitch pins were mounted. **NOTE: The floating yokes need to be installed as shown on fig. 7.**
5. For proper operation of the mower, ensure that the floating yokes are parallel to the ground.
6. Install the floating top link to the top hitch arms using the M16x100 bolt and the M16 nut.
7. Install the A-frame support to the floating top link using the M16x110 bolt and the M16 nut.
8. Install the A-frame support to the floating yokes using the M20x160 hex bolt and the M20 nut.

9. Loosen the M16x45 bolts that secure the top hitch arms to the rear support plates of the mower. Only loosen slightly. The arms must be able to move slightly up and down.
10. Tighten all hardware, ensuring all bolts and nuts have enough play to allow quick hitch adapter to move up and down.

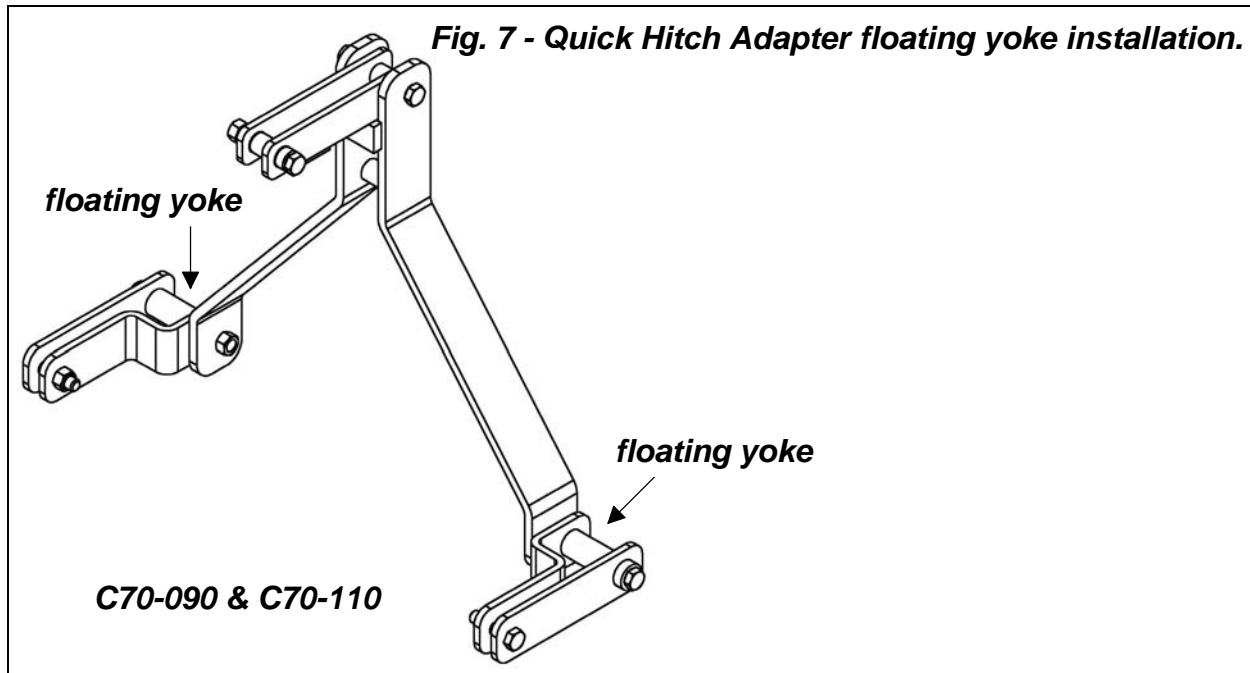

Quick Hitch Adapter operation:

After completing assembly of the adapter, the tractor lift arms should be raised and locked in a position so the floating yokes are horizontal.



CAUTION: Improper setup of the Quick Hitch Adapter can result in equipment damage. A replacement driveline must generally be installed to prevent injury or equipment damage when using the Quick Hitch Adapter.



CAUTION: If the three point hitch of the tractor is set in the lowest position, the driveline may bottom out against the Quick Hitch resulting in a bent driveline. If the mower is lifted after the driveline has been bent, it may also damage the gearbox, mounting plates, and other hardware.

4 - MAINTENANCE



DANGER: Stop engine, lock parking brake and remove key before performing any service or maintenance.

Never rely on the tractor lift system. Install blocks or stands under the mower deck to prevent it from falling.

Always use personal protection devices, such as glasses or gloves when performing maintenance.

Keep fingers out of slots to prevent injury.

4.01 - Maintenance Safety



1. Good maintenance is your responsibility.
2. Keep service area clean and dry. Be sure electrical outlets and tools are properly grounded. Use adequate light for the job at hand.
3. Make sure there is plenty of ventilation. Never operate the engine of the towing vehicle in a closed building. The exhaust fumes may cause asphyxiation.
4. Make no repair or adjustments with the tractor engine running. Before working on the machine, disengage the PTO, shut off the engine, set the brakes, and remove the ignition key.
5. Be certain all moving parts on attachment have come to a complete stop before attempting to perform maintenance.
6. Never work under equipment unless it is blocked securely.
7. Always use personal protection devices such as eye, hand and hearing protectors, when performing any service or maintenance.
8. Frequently check mower blades. They should be sharp, free of nicks and cracks and securely fastened.
9. Periodically tighten all bolts, nuts and screws and check that all cotter pins are properly installed to ensure unit is in a safe condition.
10. When completing a maintenance or service function, make sure all safety shields and devices are installed before placing unit in service.
11. Do not attempt to mount a tire unless you have the proper equipment and experience to do the job.
12. Inflating or servicing tires can be dangerous. Whenever possible, trained personnel should be called to service and/or mount tires.
13. After servicing, be sure all tools, parts and service equipment are removed.

14. Never replace hex bolts with less than grade five bolts unless otherwise specified, i.e. shear bolts¹⁰.
15. Where replacement parts are necessary for periodic maintenance and servicing, genuine replacement parts must be used to restore your equipment to original specifications. The company will not claim responsibility for use of unapproved parts and/or accessories and other damages as a result of their use.
16. Unauthorized modifications to the machine may impair the function and/or safety of the machine and reduce its life. If equipment has been altered in any way from original design, the manufacturer does not accept any liability for injury or warranty.

4.02 - Service

The accompanying illustrations show lubrication points. The chart gives the frequency of lubrication in hours, based on normal operating conditions. Severe or unusual conditions may require more frequent lubrication.

Use a good quality SAE multipurpose type grease for all locations shown. Be sure to clean fittings thoroughly before using grease gun.

Use 90 wt. gear oil in gearbox.

Hourly:

1. Check the condition of mower blades for nicks or dull edges. Sharpen if necessary.
2. Replace bent or damaged blades¹¹.
3. Also check blades for damage after hitting an obstruction.
4. Clean foreign material from mower deck and belt area.

Fig. 8 - Lubrication of wheel yokes.

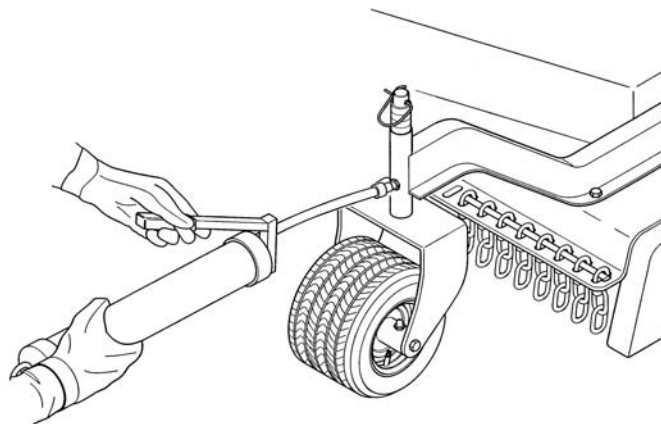

Every 8 hours:

1. **Lubricate the driveline and the wheel yokes:** Apply two or three shots of grease to the driveline cross and bearings and the telescoping shafts; apply the same amount to the wheel yokes grease fittings (**see fig. 8**). See the driveline

¹⁰ Refer to Table 1 - Torque Specifications, page 30.

¹¹ See Section 4.03 - Blade Maintenance.

manufacturer operator's manual for further information on the driveline. (Note: On older models of the C70 you may need to lubricate the wheel bearings, check wheels to see if there is a grease fitting, if so apply two or three shots of grease every 8 hours).

2. **Gearbox oil level:** Check gearbox oil level by removing the breather plug. Using a flashlight, check inside the gearbox to verify that it is approximately $\frac{1}{2}$ full. When filled correctly the oil level should be approximately halfway on the input shaft. When fully drained gearbox requires approximately 44 fl. oz. (1.4 qt.) of oil. If needed add SAE 90W gear oil.

Note: Never overfill gearbox. Oil will expand when hot. Overfilling will likely cause excess oil to blow out of breather cap.

Every 25 hours: Check hardware tightness; mower vibrations can loosen bolts. Check tightness of the hardware periodically, using **Table 1** as a guide¹².

Every 50 hours:

1. Lubricate the three spindles with two or three shots of multipurpose grease (**see fig. 9**). The top grease fittings are easily accessible from the top of the deck by simply removing the plastic dust guards.
2. Check belt tension¹³.

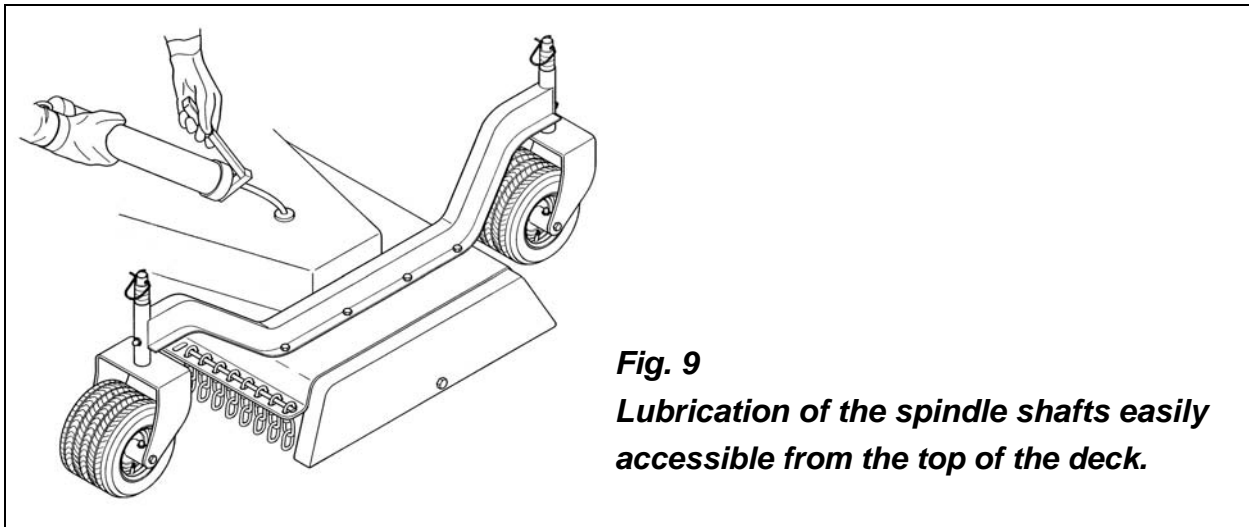

Fig. 9
Lubrication of the spindle shafts easily accessible from the top of the deck.

4.03 - Blade Maintenance



WARNING: To avoid possible injury always wear proper eye and hand protection when servicing mower blade.

¹² See Table 1, Torque Specifications, page 30.

¹³ See Section 4.04 - Belt Tension.

In order for the mower to work properly, and to always obtain a precision cut with lower HP requirements thus keeping cost down, proper blade maintenance is important. Blades must be kept sharp, at their original length and corners maintained. A blade must be replaced if, due to wear or damage, its original shape has been distorted.

Installing or removing blades

If the mower blades need to be installed, do the following:

1. The blades rotate **clockwise** viewing the mower, when lifted, from the rear. The blades must be mounted with the cutting edge in the direction of rotation and the lift wing edge towards the bottom of the deck (**see fig. 10**).
2. Insert the blade bolt through the blade and then through the spindle, taking care to assemble it as described above (**see fig. 10**). Screw on the lock nut.
3. Tighten the lock nut to 105 lb.ft.
4. To remove the blades, reverse the procedure.

Fig. 10 - Mower's spindle assembly

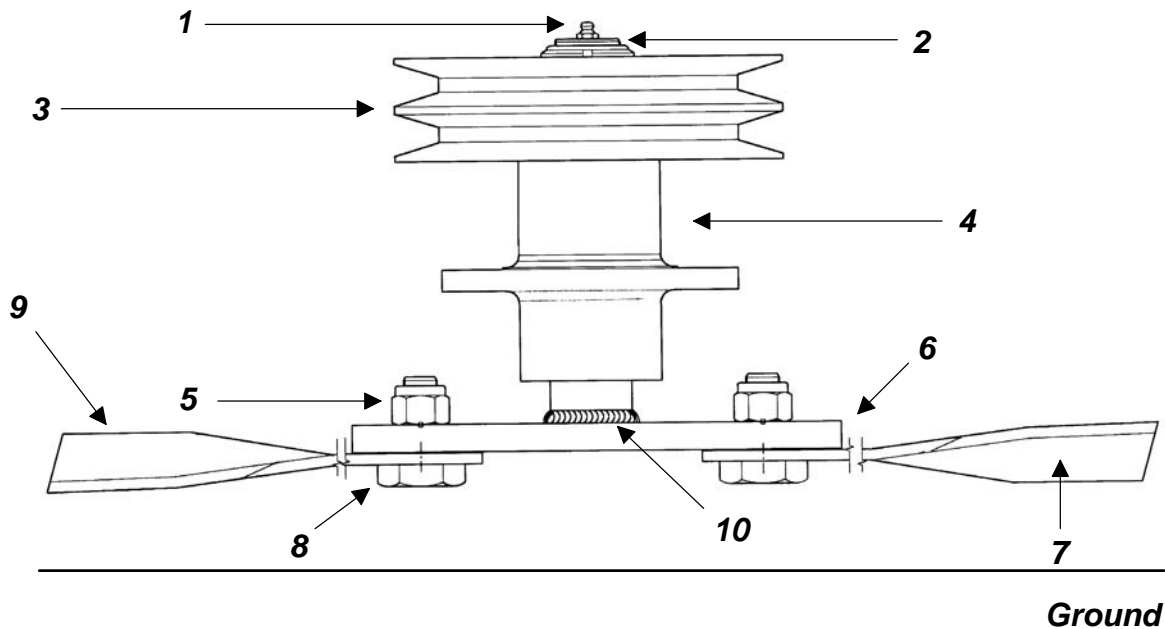

1. grease fitting
2. nut
3. pulley
4. rotor support
5. nut

6. rotor
7. blade
8. blade bolt
9. lift wing
10. shaft welded to the rotor



WARNING: Do not substitute blades or any bolt for the blade retaining bolt. Company blades and blade retaining bolts are specially made for this application.

Using non original parts can effect the quality of cut and may also cause damage to the mower.



DANGER: Proper torque must be used when tightening the blade retaining bolt. If these safety precautions are not followed, the blade could come off during operation and be thrown hundreds of feet from the mower.

Sharpening blades

Blade sharpening is extremely important in order to get the best cutting results. Sharp blades permit a high quality cut and also reduce HP thus lowering cost.

To sharpen blades, first remove them following the above instructions.

Place the blade in a vise and sharpen them by using a hand file or grinder. **Do not sharpen the blades to a sharp cutting edge.** The cutting edge should be between $\frac{1}{64}$ " to $\frac{1}{32}$ " to prevent excessive pitting and dulling of the blades. Sharpen both ends of the blade equally for balance and always maintain corners. Always keep all three blades sharpened equally in order to maintain balance.



CAUTION: Unbalanced or warped blades can cause damage to the mower and/or personal injury. Replace damaged blades before operating the mower. Sharpen both ends of the mower blades equally or until the blade is balanced.

4.04 - Belt Tension

Belt tension control

Check the belt tension (see fig. 11) by applying a force of 12-15 lb. pushing against the belt halfway between the pulleys. The belt deflection should be between $\frac{5}{16}$ "- $\frac{3}{8}$ ".

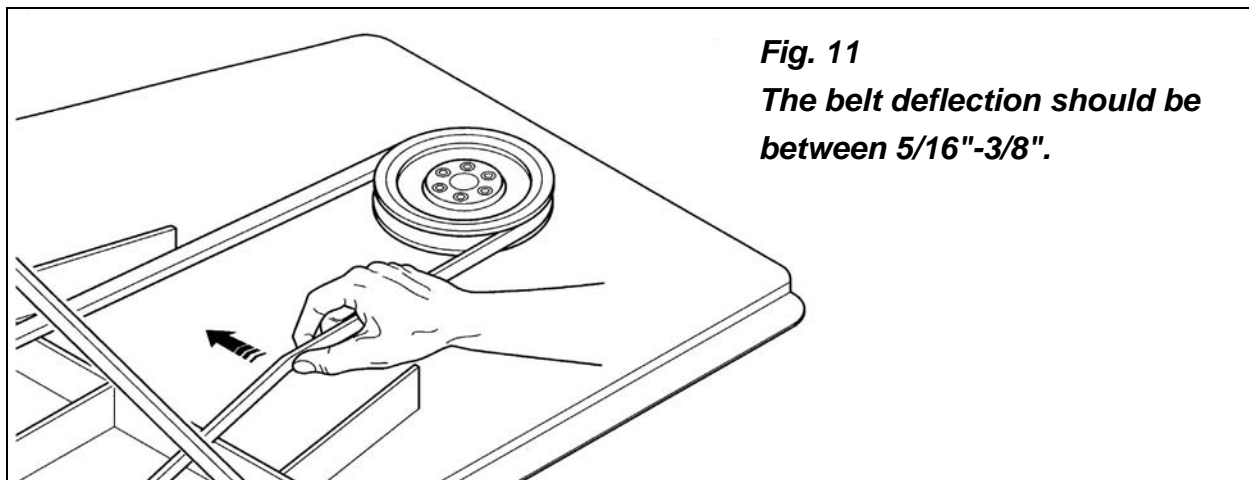

Fig. 11
The belt deflection should be between $\frac{5}{16}$ "- $\frac{3}{8}$ ".

Belt tension adjustment

To adjust the tension do the following (**see fig. 12**):

1. Remove belt shields. Clean foreign material from the mower deck and belt area.
2. Loosen the four nuts holding the gearbox support plate to the central plate.
3. Loosen the two blocking nuts on the adjustment bolt.
4. Turn the adjustment bolt clockwise until the proper belt tension is reached. This will draw the gearbox support plate to the rear, thus tightening the belts.
5. Tighten the two blocking nuts on the adjustment bolt.
6. Retighten the four nuts holding the gearbox support to the central plate.
7. Reinstall the belt shields.

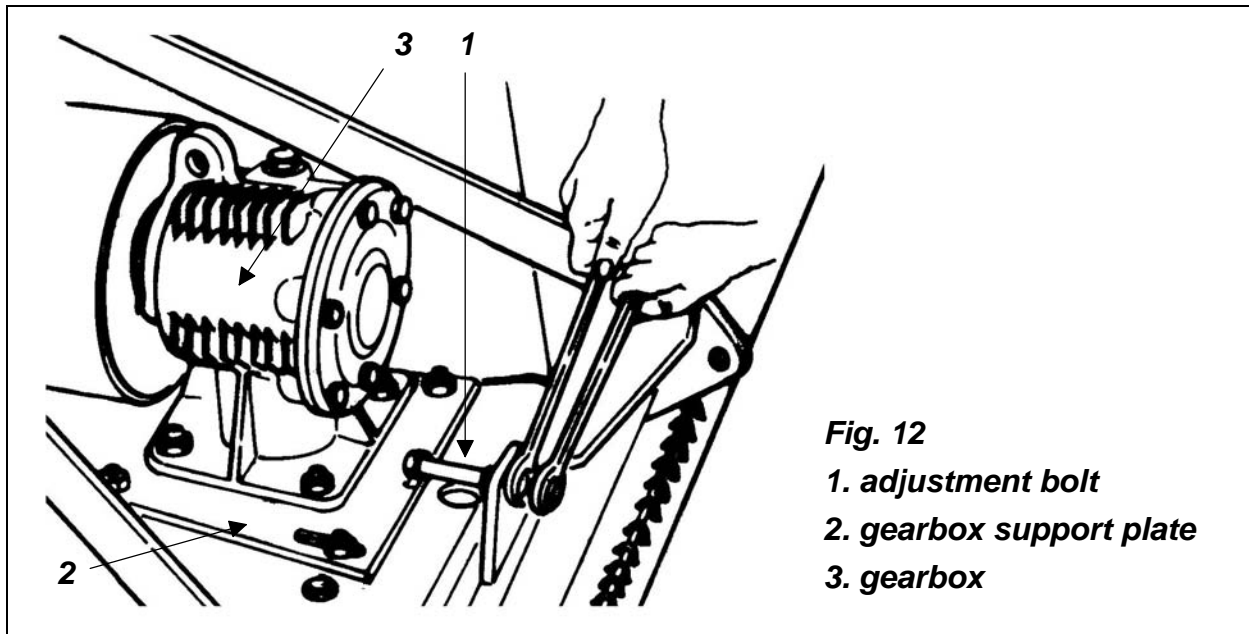

Fig. 12

1. *adjustment bolt*
2. *gearbox support plate*
3. *gearbox*

4.05 - Belt Replacement

If the belts have been stretched or damaged to the point where the proper tension cannot be obtained they must be changed.

IMPORTANT: When replacing belts always remember to replace both belts at the same time. Replacing belt on only one side of the mower deck will cause unnecessary belt slippage and premature belt failure.

To replace belts do the following:

1. Remove belt shields. Clean foreign material from the mower deck and belt area.
2. Loosen the four nuts holding the gearbox support plate to the central plate.
3. Loosen the two blocking nuts on the adjustment bolt.
4. Turn the adjustment bolt counter clockwise, pushing the gearbox support plate forward until all tension is released (**see fig. 12**).
5. Loosen rear nuts holding central plate (do not remove them).
6. Remove front nuts holding central plate.

7. Lift the front of the central plate and remove old belts.
8. Replace new belts (**see fig. 13**). Loop the first belt over the left spindle and around the lower groove of the center spindle pulley and the lower groove of the gearbox drive pulley. The second belt connects the upper grooves of the center spindle pulley and the gearbox drive pulley with the right spindle pulley.
9. Lower central plate.
10. Replace front nuts. Tighten front and rear nuts holding down central plate.
11. Turn the adjustment bolt clockwise until the proper belt tension is reached. This will draw the gearbox support plate to the rear, thus tightening the belts.
12. Tighten the two blocking nuts on the adjustment bolt.
13. Retighten the four nuts holding the gearbox support to the central plate and replace the belt shields.

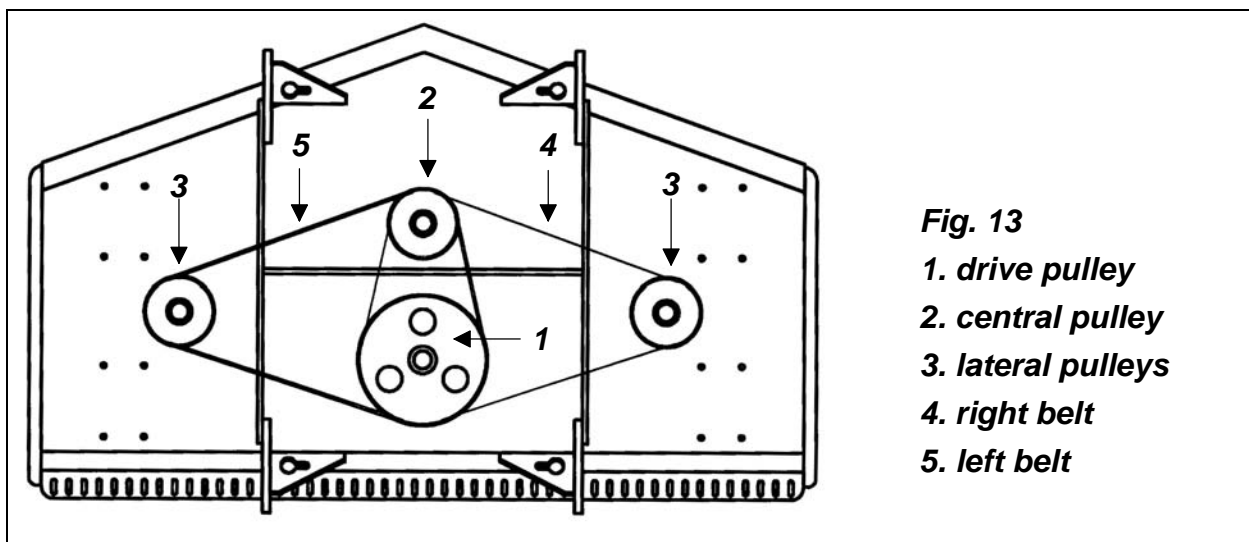

Fig. 13
1. drive pulley
2. central pulley
3. lateral pulleys
4. right belt
5. left belt

4.06 - Driveline



DANGER: Only use the original driveline supplied with this mower and always with the safety shielding. Carefully read and file away the driveline operator's manual supplied by the manufacturer. The following does not substitute the information found in the driveline manual.

IMPORTANT: Always check driveline length during initial setup and when connecting to a different tractor.

In the collapsed position the driveline should be approximately 2" from bottoming out to prevent possible damage to the tractor or implement. When the driveline is in the maximum extended position, the ideal minimum overlap of the two halves should be approximately 6" (**see fig. 14**).

If determined that the driveline is too long, follow these procedures to adjust the length:

1. Separate the two driveline halves. Connect one half to the tractor PTO and the other half to the mower.
2. Raise and lower the mower with the 3 point hitch to find the position where the driveline is shortest. Hold the half shafts side by side and mark the desired length on the outer female tube guard leaving a 1½" gap between the end of the guard tube and bell guard.
3. Cut off both guard tubes the same amount as marked in step 2.
4. Shorten both drive tubes the same amount as guard tubes.
5. De-burr and clean filings from drive tubes and apply grease to outside of inner telescoping tube.
6. Reassemble the driveline halves and connect to tractor and mower. Raise and lower mower again to be sure driveline does not bottom out in its shortest position and has a minimum overlap of 6" in the longest position.
7. Install both driveline safety chains. One should be hooked in a hole on the outer driveline yoke shield and to the tractor to restrict outer shield rotation. The second one should be hooked in a hole on the inner driveline yoke shield and to the implement to restrict inner shield rotation.

If determined that the driveline is too short for your tractor, contact your local dealer.

Fig. 14

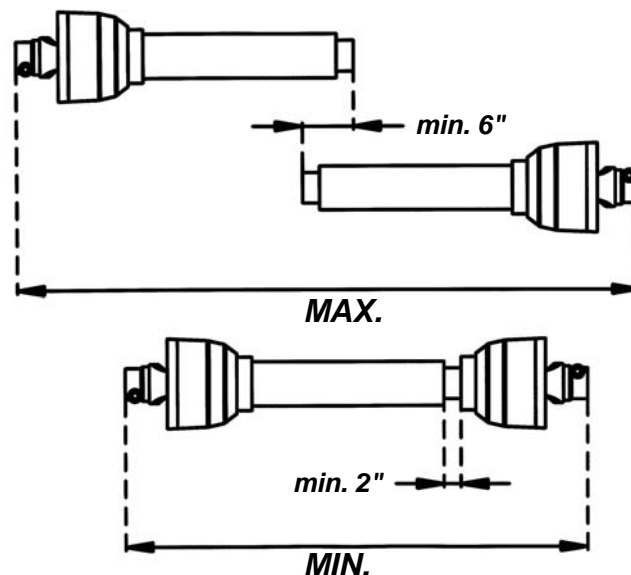

CAUTION: Always work with the driveline as straight as possible. This will prolong its life and that of its components. It is advised not to work at an angle greater than 15 degrees.

4.07 - Transport

Before raising the mower for transport, the tractor top link must be adjusted so when lifted, the rear of the machine is higher than the front (the mower's nose is tilted

downward). To do this, shorten the tractor top link until the top hitch plate is locked forward and no longer able to pivot. This will keep the mower locked in position and minimize the shaking and bouncing during transport which can damage the hitch or frame.

When raising the mower be sure the PTO driveline does not hit either the mower or the tractor. During transport the mower should not be lifted over 14"-16" from the ground.



CAUTION: Make sure PTO is disengaged and blades have stopped turning before raising mower to full transport position.

Do not tow tractor and mower behind other vehicles. Use a properly equipped trailer with heavy tie-downs for towing operations.

Before transporting:

1. Disengage PTO.
2. Shorten tractor top link until top hitch plate is locked.
3. Raise machine and lock rockshaft control lever.
4. Always select a safe ground speed that is appropriate for the terrain.
5. Beware of traffic on public roads. Install a SMV (Slow Moving Vehicle) sign when traveling on roads or streets.
6. Reduce ground speed when turning and take care that the mower does not strike obstacles such as trees, fences or buildings.

4.08 - Storage









CAUTION: Following operation, or when unhooking, stop the tractor, set the brakes, disengage the PTO, shut off the engine and remove the ignition key. Store the unit in an area away from human activity. Do not permit children to play on or around the stored unit. Make sure all parked machines are on a hard, level surface and engage all safety devices.

After seasonal use it is important to perform the following for prolonged storage:

1. Wash the mower carefully.
2. Inspect the mower and replace worn or damaged parts.
3. Tighten all hardware.
4. Grease all areas indicated under Maintenance.
5. Loosen the belts if the mower is to be stored for an extended length of time.
6. Cover the mower from the elements in order to have it in perfect condition for the start of the next season.

TABLE 1 - TORQUE SPECIFICATIONS

Metric (ISO) treaded bolts head marking							Inch (SAE) treaded bolts head marking								
	Class 5.8		Class 8.8		Class 10.9			Grade 2		Grade 5		Grade 8			
Bolt size mm	Thread mm	N.m	ft-lb	N.m	ft-lb	N.m	ft-lb	Bolt size inch	Thread inch tpi	N.m	ft-lb	N.m	ft-lb	N.m	ft-lb
M5	0.8	4	3	6	4	9	7	1/4"	20	7	5	11	8	16	12
M6	1	6	4	10	7	15	11	1/4"	28	8	6	13	10	19	14
M8	1.25	16	12	25	18	36	27	5/16"	18	15	11	24	17	33	25
M8	1	17	13	26	19	38	28	5/16"	24	17	13	26	19	37	27
M10	1.5	31	23	48	35	71	52	3/8"	16	27	20	42	31	59	44
M10	1.25	33	24	51	38	75	55	3/8"	24	31	23	47	35	67	49
M10	1	35	26	53	39	78	58	7/16"	14	43	32	67	49	95	70
M12	1.75	54	40	84	62	123	91	7/16"	20	48	36	75	55	106	78
M12	1.5	56	41	87	64	128	94	1/2"	13	66	48	102	75	144	106
M12	1.25	59	44	90	66	133	98	1/2"	20	75	55	115	85	163	120
M14	2	84	62	133	98	195	144	9/16"	12	95	70	147	109	208	154
M14	1.5	94	69	142	105	209	154	9/16"	18	106	79	164	121	232	171
M16	2	131	97	206	152	302	223	5/8"	11	132	97	203	150	287	212
M16	1.5	141	104	218	161	320	236	5/8"	18	149	110	230	170	325	240
M18	2.5	181	133	295	218	421	310	3/4"	10	233	172	361	266	509	376
M18	2	196	145	311	229	443	327	3/4"	16	261	192	403	297	569	420
M18	1.5	203	150	327	241	465	343	7/8"	9	226	167	582	430	822	606
M20	2.5	256	189	415	306	592	437	7/8"	14	249	184	642	473	906	668
M20	1.5	288	212	454	335	646	476	1"	8	339	250	873	644	1232	909
M22	2.5	344	254	567	418	807	595	1"	12	371	273	955	704	1348	995
M22	1.5	381	281	613	452	873	644	1-1/8"	7	480	354	1077	794	1746	1288
M24	3	444	327	714	526	1017	750	1-1/8"	12	539	397	1208	891	1958	1445
M24	2	488	360	769	567	1095	808	1-1/4"	7	677	500	1519	1120	2463	1817
M27	3	656	484	1050	774	1496	1103	1-1/4"	12	750	553	1682	1241	2728	2012
M27	2	719	530	1119	825	1594	1176	1-3/8"	6	888	655	1992	1469	3230	2382
M30	3.5	906	668	1420	1047	2033	1499	1-3/8"	12	1011	746	2268	1673	3677	2712
M30	2	1000	738	1600	1180	2250	1659	1-1/2"	6	1179	869	2643	1949	4286	3161
M36	4	1534	1131	2482	1830	3535	2607	1-1/2"	12	1326	978	2974	2194	4823	3557

When using lock washers with nuts, increase torque values by 5%.

TABLE 2 - C70 GROOMING MOWERS - TECHNICAL FEATURES

Series C70, Rear Discharge, for tractors up to 70 HP, PTO 540 rpm, 3 point hitch cat. 1											
Model	HP	Working width	Overall width	Weight lb.	Rotor rpm/min	Blades tip speed ft/min	# of blades	Cutting height	# of belts & type	# of wheels & size	Driveline 1 3/8"
C70-090A C70-090H	30-70	90"	92"	1137 1237	1750	14106	6	1.3"-5.3"	2 CX	4 - 13"x6.5" air 4 - 12"x4" hard	ASAE 4 th cat
C70-110A C70-110H	40-70	110"	112"	1290 1390	1562	14998	6	1.3"-5.3"	2 CX	4 - 13"x6.5" air 4 - 12"x4" hard	ASAE 4 th cat

5 - REPAIR PROCEDURES



CAUTION: All repair procedures must be done by authorized dealerships. It is not recommended that untrained individuals perform any repair work. The following operations are detailed for qualified personnel only.

5.01 - Gearbox

To remove the gearbox do the following:

1. Remove the belt guards.
2. Loosen the nuts holding the gearbox support plate (**see fig. 12**).
3. Loosen the nut and turn the bolt in order to push the gearbox forward and release tension on the belts (**see fig. 12**).
4. Remove the belts¹⁴.
5. Remove the nuts holding the central plate to the frame.
6. Remove the nut holding the pulley to the gearbox pinion shaft. Remove the pulley.
7. Unbolt the nuts holding the gearbox support plate to the central plate (**see fig. 12**). Remove gearbox and gearbox support plate.
8. Unbolt the nuts holding the gearbox to the gearbox support plate. Remove the gearbox.

If it is necessary to replace any part on the inside of the gearbox, it is important to replace oil seals or gaskets to ensure a tight fit when reassembling.

To replace the gearbox, follow the above instructions in reverse order.

5.02 - Blade Spindle

To remove a blade spindle do the following:

1. Remove the belts¹⁵.
2. Remove the safety nut holding the pulley to the spindle shaft. Remove the pulley.
3. Remove the bolts holding the spindle assembly to the deck and remove the assembly.
4. Press out the spindle shaft.
5. If necessary remove and replace the bearings from the rotor using presses or extractors. Take care not to damage the oil seals. Replace them if necessary.

¹⁴ See Section 4.05 - Belt Replacement.

¹⁵ See Section 4.05 - Belt Replacement.

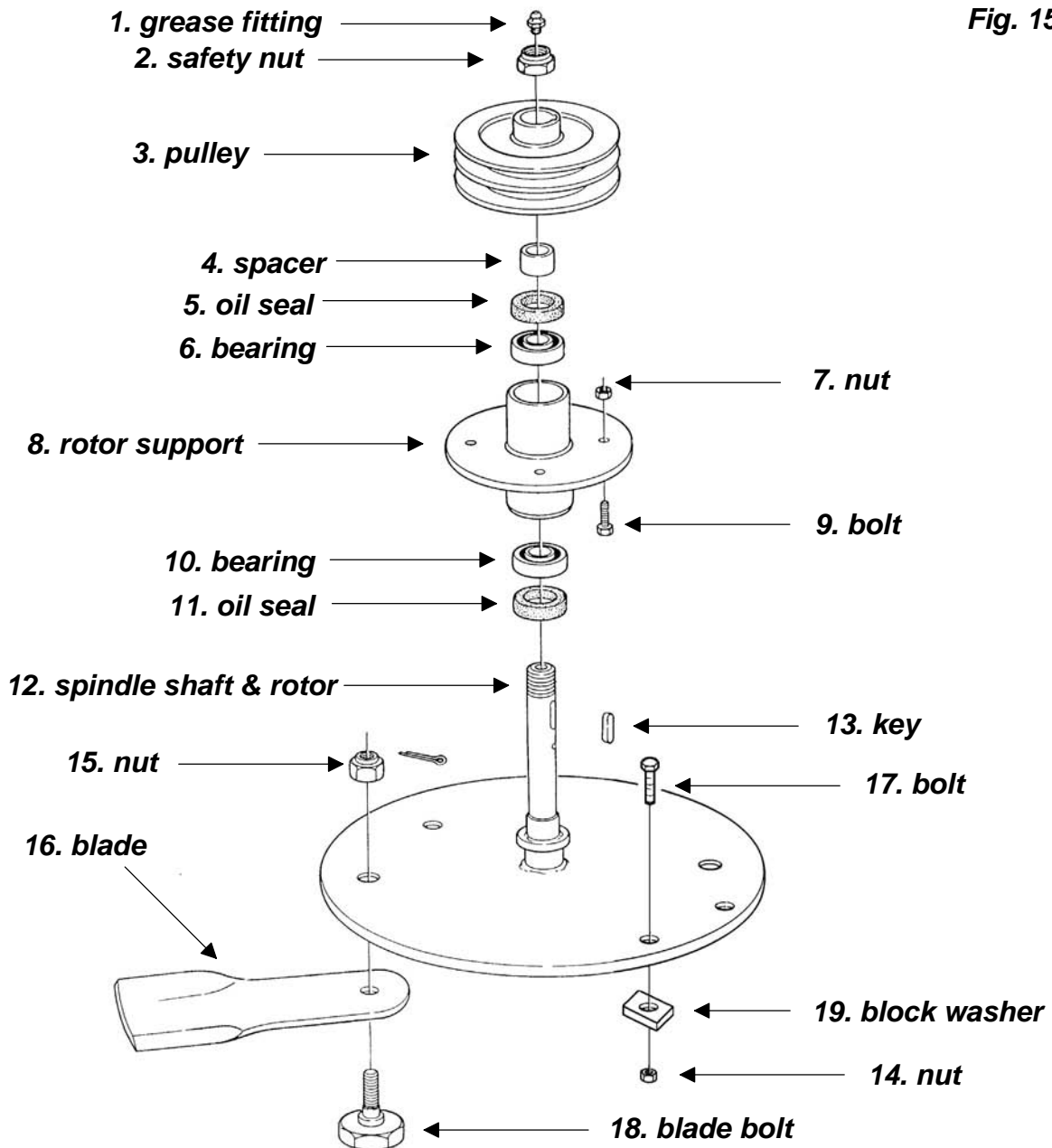

To reassemble the blade spindle, do the following:

1. Clean the spindle housing support. Remove shavings and/or burrs.
2. Rub oil on the mounting surfaces. Press the bearing races into the rotor support (see fig. 15).
3. Apply a layer of grease to the inner ring of the bearing. Pack the bearings with grease.
4. Carefully lubricate the oil seal and assemble it on the spindle shaft with the lip turned down toward the blade mounting plate.
5. Place the bearing over the spindle shaft.

6. Assemble the rotor support over the spindle shaft, taking care not to damage the oil seal.
7. Place the upper bearing, the adjustment spacer and the oil seal (assemble it with the lip towards the bearing) over the spindle shaft. Be sure all parts are lubricated prior to assembly. Take care not to damage the seal.
8. Bolt the spindle assembly to the deck.
9. Place the key in the keyway and mount the pulley onto the shaft.
10. Tighten the locking nut while turning the spindle. Tighten the spindle until resistance is felt. Tighten until there is no up and down play in the pulley.
11. Back off $\frac{1}{12}$ of a turn so the spindle turns without resistance.
12. With rubber mallet, tap on the top of the spindle to set the bearings.
13. Check spindle to ensure that it is still turning freely left and right.
14. Tighten the nut and check again to ensure that the spindle is still turning freely.
15. Check to ensure that there is no excessive play in the bearing.
16. If play is present, loosen the nut and tap on spindle again and tighten up and check movement again.
17. If spindle appears to be too tight, loosen the nut about $\frac{1}{12}$ of a turn and check again.
18. Be sure the grease fitting is in the shaft (**see fig. 15**).
19. Replace the belts and the belt covers.
20. Grease the spindle assembly.

5.03 - Suggested Spare Parts

It is suggested that the following spare parts be kept on hand for the mower at all times to prevent a minor problem from delaying work.

Description	Quantity
Blades	6
Blade bolts	6
Belts	2

6 - TROUBLESHOOTING



WARNING: Be sure tractor engine is off, parking brake is locked, and key is removed before making any adjustments.

PROBLEM	POSSIBLE CAUSE	SOLUTION
Uneven cutting.	Ground speed too fast. Blades need sharpening. Caster wheels uneven.	Shift to lower gear. Sharpen blades. Adjust wheel position.
Blades turning but not cutting.	Direction of blades is wrong.	Blade should turn clockwise when you face deck bottom. See Blades Maintenance section.
Belt slippage.	Lack of tension. Object clogging mower. Debris in pulleys. Only one belt replaced.	Tighten belt. Remove object. Clean pulleys. Always replace both belts.
Mower vibrates.	Object wrapped around blade. Belts damaged.	Remove object. Replace belts.
Belt squeal.	Belts slipping.	Tighten belts.
Grass build up at exit.	Wet grass. Grass too high. Tractor rpm too slow.	Allow grass to dry. Raise mower, shift to lower gear, make two passes over grass. Mow grass high 1st pass, 2nd pass cut to desired height. Increase tractor rpm, check engine and PTO speeds.
Belts are tight when installing.	Wrong belt size. Installed belts incorrectly.	Check belt size. See Replacing Belts section.
Streaking conditions in swath.	Too wet to mow. Blades cannot cut grass pressed down by wheels. Dull blades. Blades worn down, preventing overlap.	Allow grass to dry. Maintain engine speed and shift to lower gear. Sharpen blades. Change blades.

PROBLEM	POSSIBLE CAUSE	SOLUTION
Cut grass windrows.	Ground speed too low. Tractor rpm too slow.	Increase ground speed. Increase tractor rpm, check engine and PTO speeds.
Oil blowing out of gearbox breather cap.	Gearbox overfilled.	Use a siphon pump to drain excess oil out of gearbox.

7 - PRE-DELIVERY CHECKLIST

To the dealer: Inspect the machine thoroughly after assembly to assure it is functioning properly before delivering it to the customer. The following checklist is a reminder of points to cover. Check off each item as it is found satisfactory or after proper adjustment is made.

- Gearbox oil level.
- Guards and shield properly fastened.
- Lubrication of grease fittings.
- All hardware properly tightened.
- All decals properly located and readable (**see fig. 2**).
- Blades properly installed, blade bolts and nuts tightened.
- Overall condition (touch up scratches, clean and polish).
- Test run, check for excessive vibration or overheating of bearings.
- Operator's Manual.

Review the Operator's Manual with the customer. Explain the following:

- Warranty.
- Safe operation and service.
- Correct machine installation and operation.
- Daily and periodic lubrication, maintenance and inspections.
- Troubleshooting.
- Operational procedures and storage.
- Parts and service.
- Fill out the Pre-Delivery Checklist and Warranty Registration form.
- Give customer the Operator's Manual and encourage the customer to read the manual carefully.

IMPORTANT: Warranty is not valid unless Pre-Delivery Checklist and Warranty Registration form in Operator's Manual is completed in detail and mailed to the Company.

Model Number: _____

Serial Number: _____

Delivery Date: _____

Dealer's Signature: _____

8 - WARRANTY

BEFCO's responsibility will be limited to substitution of the acknowledged defective merchandise to the same place of delivery as the previous one was supplied.

1. LIMITED WARRANTY

BEFCO, Inc. herein referred to as the Company, warrants its machines and related accessories, hereafter referred to as the Machine, to be free from defects in material and workmanship, for a period of twelve (12) months from the date of invoice to the first registered owner; this limited warranty does not apply to common wear items and excludes belts, shear pins, oil, grease, tires, tubes, hydraulic hoses, knives and PTO shafts.

Labor will be reimbursed at \$40.00 per hour based on BEFCO's time schedule.

Cost of transport to the servicing dealer is the responsibility of the customer.

Warranty coverage shall not be transferable from the first owner to any subsequent owner.

2. DISCLAIMER OF ALL OTHER WARRANTIES AND REMEDIES

Neither the Company nor any company affiliated with the Company makes any warranties, representations or promises, expressed or implied, as to the quality, performance or application of its products other than those set forth herein and does not make any implied warranty of merchantability or fitness.

The only remedies the purchaser has in connection with the breach, or performance of any warranty on the Company's Machine are those set forth herein. In no event will the dealer, the Company, or any company affiliated with the Company, be liable for:

- a. Injuries or damages of any kind or nature, direct, consequential or contingent to person or property.
- b. Any expenses incurred by the owner to repair, replace or rework any allegedly defective item.
- c. Any loss, cost, forfeiture or damages (including loss of profits; loss of crops; loss because of delay in field operations; any expenses or loss incurred for labor, supplies, substitute machine rental; liabilities of the owner to its customers or third persons; and all other consequential damages, losses, liabilities or damages for any other reasons) whether direct or indirect, and whether or not resulting from or contributed to by the default or negligence of the Company, its agents, employees and subcontractors which might be claimed as a result of the use or failure of the equipment delivered.

The Company's liability based on this limited warranty or any other applicable laws shall be limited to replacement or refund of the purchase price of the product.

The limited warranty extended herein gives you specific rights and you may also have other rights which vary from state to state. Neither the dealer nor the Company personnel has the authority to make any representation or to modify the terms and limitations of this warranty in any way.

Other than the limited warranty extended hereby there is no other expressed warranty in connection with the design, safety or use of any of the Company's products except as to title. All implied warranties are expressly disclaimed pursuant to the terms of this warranty.

3. CUSTOM WORK

If the Machine is used for commercial purposes such as custom work, the period warranted for the Machine is limited to six (6) months from the date of delivery to the first registered owner and does not cover any labor charges incurred.

4. RENTAL

If the Machine is used for rental purposes the period warranted for the Machine is limited to thirty (30) days from the date of delivery to the first registered owner and does not cover any labor charges incurred.

5. REGISTRATION

In order to qualify for coverage on this limited warranty, the product and name of the original purchaser must be registered with the Company by a completed Machine Pre-Delivery Checklist and Warranty Registration along with a copy of the dealer's invoice to the first registered owner to the Company within fourteen (14) days after the date of delivery to the original purchaser.

6. WARRANTY SERVICE

Warranty Service must be performed by a dealer authorized by BEFCO. If the warranty service requested is approved, the owner shall pay only for labor beyond the rate allowed, for overtime labor, and for any mileage charge for transporting the equipment to and from the dealer's shop. It is assumed that the dealer has the appropriate general and special tools to service the Machine. Time required for replacement of knives, oil, grease and to remove excessive dirt from the Machine is not subject to reimbursement by the Company. The owner is required to clean the Machine before presenting it to the dealer for service work. The Machine must be delivered within thirty (30) days after failure date by the owner to the dealer to be eligible for warranty consideration.

7. UNAPPROVED SERVICE OR MODIFICATION

All obligations of the Company under this limited warranty shall be terminated if:

- a. Proper service and operation instructions as outlined in the Operator's Manual and on the instruction sticker on the Machine, are not followed.
- b. The Machine is modified or altered in any way not approved by the Company.
- c. The Company does not receive a copy of the dealer's invoice to the first registered owner within fourteen (14) days from the date of delivery.
- d. The Company has not been paid in full, by the dealer, for the Machine.

8. ACCIDENTS AND NORMAL MAINTENANCE

This limited warranty covers defective material and workmanship. It does not cover depreciation or damage caused by normal wear, accidents, improper maintenance, improper protection or improper use. The costs of normal maintenance or repairs for accidents or improper use, and related labor will be borne by the owner.

9. REPLACEMENT PARTS

BEFCO, Inc. warrants replacement parts to be free from defect in material and workmanship for a period of thirty (30) days from the date of delivery to the original purchaser.

WARRANTY REGISTRATION

BEFCO, Inc.
P.O. Box 6036
Rocky Mount, NC 27802-6036

Tel: (252) 977.9920 - Fax: (252) 977.9718

Dealer _____ Acct. # _____	Retail Customer _____
Street _____ Country _____	Street _____
Town _____ State _____ Zip _____	Town _____ State _____ Zip _____
Date of delivery _____ Invoice # _____	Phone _____
Model # _____ Serial # _____	
<p>Pre-Delivery Checklist:</p> <p><input type="checkbox"/> Oil in gearbox.</p> <p><input type="checkbox"/> Greased fittings.</p> <p><input type="checkbox"/> Safety guards in place.</p> <p><input type="checkbox"/> All hardware tight.</p> <p><input type="checkbox"/> Bolts torqued correctly.</p> <p><input type="checkbox"/> Attached unit to tractor. Yes/No.</p> <p><input type="checkbox"/> Field adjusted. Yes/No.</p> <p><input type="checkbox"/> Test run. Dry/Infield.</p> <p><input type="checkbox"/> Safety decals.</p> <p><input type="checkbox"/> Operator's Manual.</p> <p>The machine described above, had been prepared for delivery according to the Pre-Delivery Checklist and the Customer has been instructed in its care and operation and the condition of warranty.</p>	<p>Tractor make: _____</p> <p>Model: _____; HP _____</p> <p>Type of operation: Private homeowner, Landscaping, Commercial maintenance, Golf Course, Municipality, Turf Farm, others: _____</p> <p>Approximate number of acres machine will be used on annually: _____</p> <p>I hereby acknowledge that: I have received and accepted delivery of the machine described. The equipment was checked thoroughly for loose or missing parts and has been adjusted in accordance with the Pre-Delivery Checklist. I have read and understand the nature and extent of the warranty and understand clearly that there were and are no other representations of warranties either expressed or implied, made by anyone. I have been advised on proper operation, maintenance and lubrication procedure of this equipment. I have been instructed on and do understand the application, limitation and capacities this equipment was designed and recommended for, all as described in the Operator's Manual and literature published by the Company.</p>
Inspected by: _____	
Date: _____	Date: _____
Dealer's Signature: _____	Customer's Signature: _____

This registration along with a copy of the invoice must be sent to BEFCO, Inc. within 14 days of date of purchase.

Sender:

Fold here

*Place stamp
here*

BEFCO, Inc.

Warranty Department

P.O. Box 6036

Rocky Mount, NC 27802-6036

Cut along this line



BEFCO[®]

Parts Manual

CYCLONE

Three Spindle Grooming Mower

C70-090, C70-110

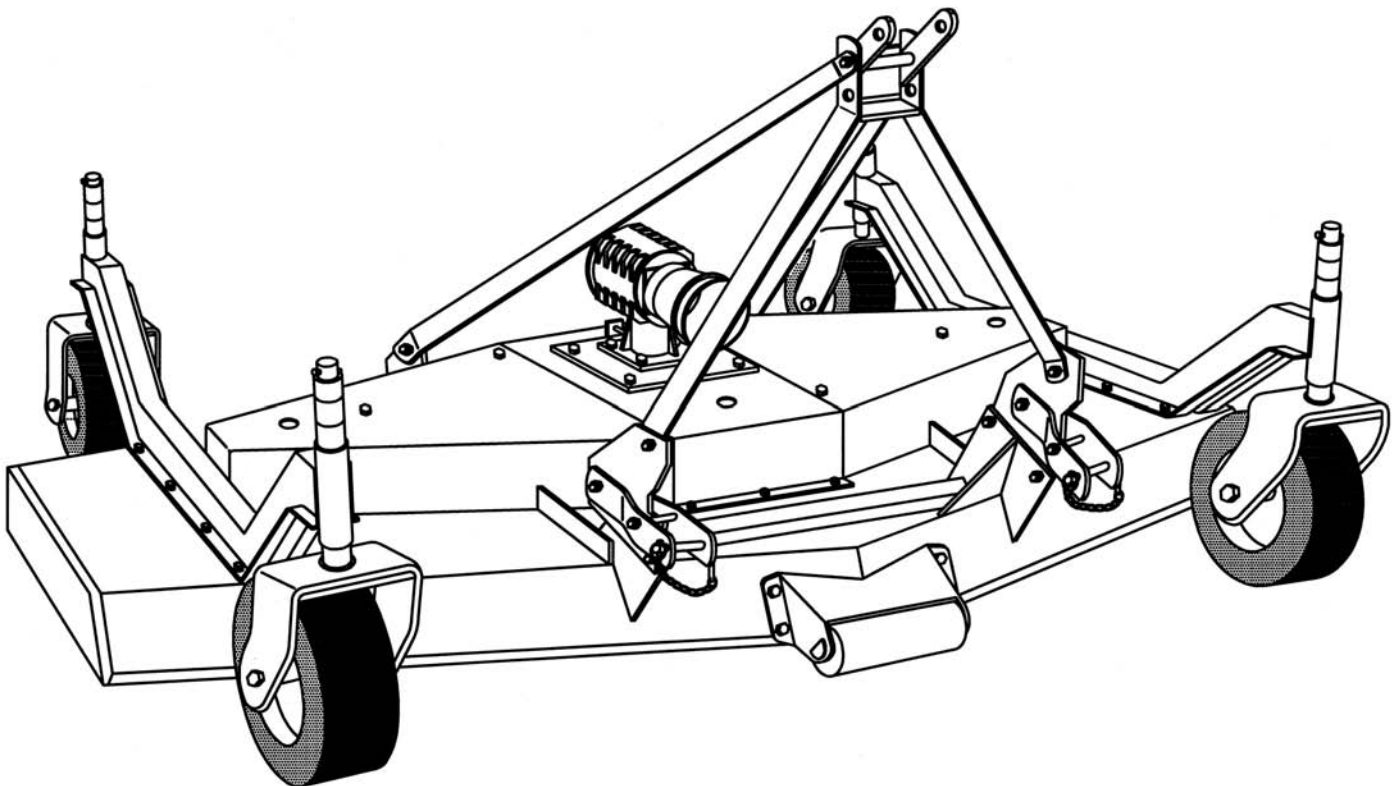

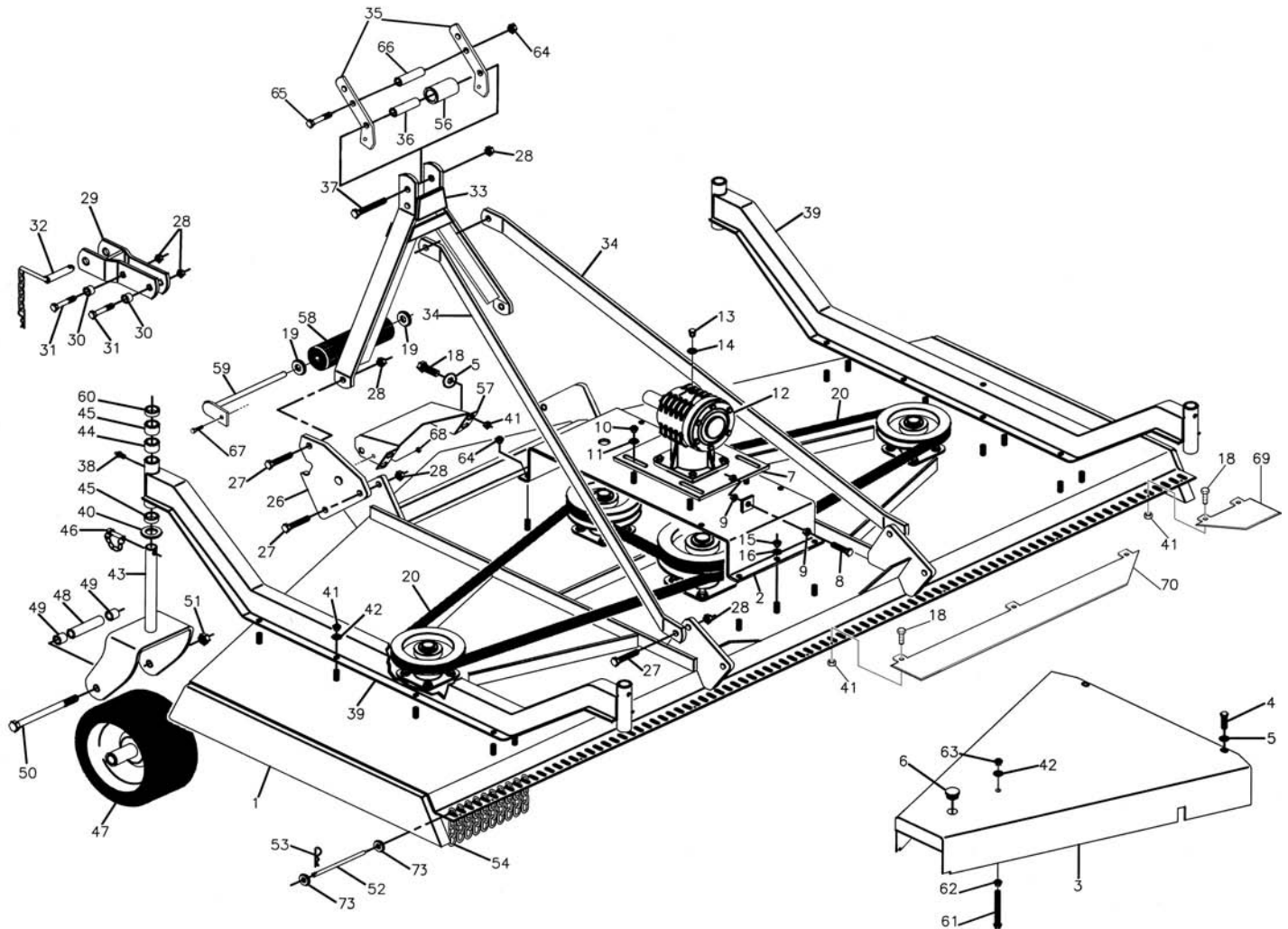

Ref.	Part #	Description	Qty.
1	016-7002	Frame 90"; C70-090	1
	026-7002	Frame 110"; C70-110	1
2	016-7052	Central plate	1
3	016-7061	Belt shield w/tab; C70-090 First version only	2
	016-7062	Belt shield; C70-090 Ver. A & above	2
	026-7061	Belt shield w/tab; C70-110 First version only	2
	026-7062	Belt shield; C70-110 Ver. A & above	2
4	003-3176	Bolt HH M10-1.50x25 C8.8 Z F	4
5	000-2034	Washer flat Ø10 W	8
6	000-6647	Cap	3
7	004-4187	Support plate, gearbox	1
8	006-7082	Bolt SP M12-1.75x122 C8.8 P F	1
9	000-1106	Nut HH M12-1.75 C6 Z MD	2
10	009-4139	Nut ES M12-1.75 TN Z	4
11	007-6106	Washer fender Ø12 Z	4
12	050-0614	Gearbox, complete	1
13	000-1107A	Breather cap	1
14	000-6691	Gasket	1
15	000-3038	Nut HH M12-1.75 C6 Z TK	3
16	000-1077	Washer lock Ø12 Z	3
18	000-6349	Bolt HH M10-1.50x20 C8.8 Z F	24
19	000-8568	Washer flat Ø16 W	2
20	004-4253	Belt CX 98 C70-090; Ver. A (#231019) & below	2
	006-7168	Belt CX 108 C70-110; Ver. A (#231019) & below	2
	006-7169	Belt CX 96 C70-090; Ver. B (#231020) & above	2
	006-7170	Belt CX 106 C70-110; Ver. B (#231020) & above	2
26	006-7251	Linking plate	2
27	000-2365	Bolt HH M16-2.00x50 C8.8 Z P	8
28	000-5581	Nut PT M16-2.00 C6 Z TK	13
29	006-7257	Lower hitch arm w/hitch made in 2 pieces; Ver. C & below	4
	006-7256	Lower hitch arm w/hitch made in 1 piece; Ver. D & above	2
30	000-6827	Spacer	4
31	003-3218	Bolt HH M16-2.00x55 C8.8 Z P	4
32	003-8346	Hitch pin	2
33	006-7274	Top hitch support; Ver. A (#231019) & below	2
	006-7271	Three point hitch; Ver. B only ¹⁶	1
	006-7275	Three point hitch; Ver. C & above	1
34	016-7279	Top hitch arm; C70-090 Ver. A (#231019) & below	2
	026-7279	Top hitch arm; C70-110 Ver. A (#231019) & below	2
	006-7276	Top hitch arm; C70-090 Ver. B (#231020) & above	2
	006-7277	Top hitch arm; C70-110 Ver. B (#231020) & above	2
35	000-6828	Upper plate (U shaped); Ver. A (#231019) & below	1
	004-4069	Three point hitch joint (straight, 2 holes); Ver. B only ¹⁷	2
	006-7282	Three point hitch joint (straight, 2 holes); Ver. C & D ¹⁸	2
	006-7285	Three point hitch joint (L shaped, 3 holes); Ver. E & above ¹⁹	2

¹⁶ Three point hitch #006-7271 is no longer available, part #006-7275 should be used instead.

¹⁷ A limited quantity of part #004-4069 is still available, after which both hitch joints should be replaced with part #006-7285.

¹⁸ A limited quantity of part #006-7282 is still available, after which both hitch joints should be replaced with part #006-7285.

¹⁹ Part #006-7285 is interchangeable with part #006-7282 provided both "three point hitch joints" are replaced.

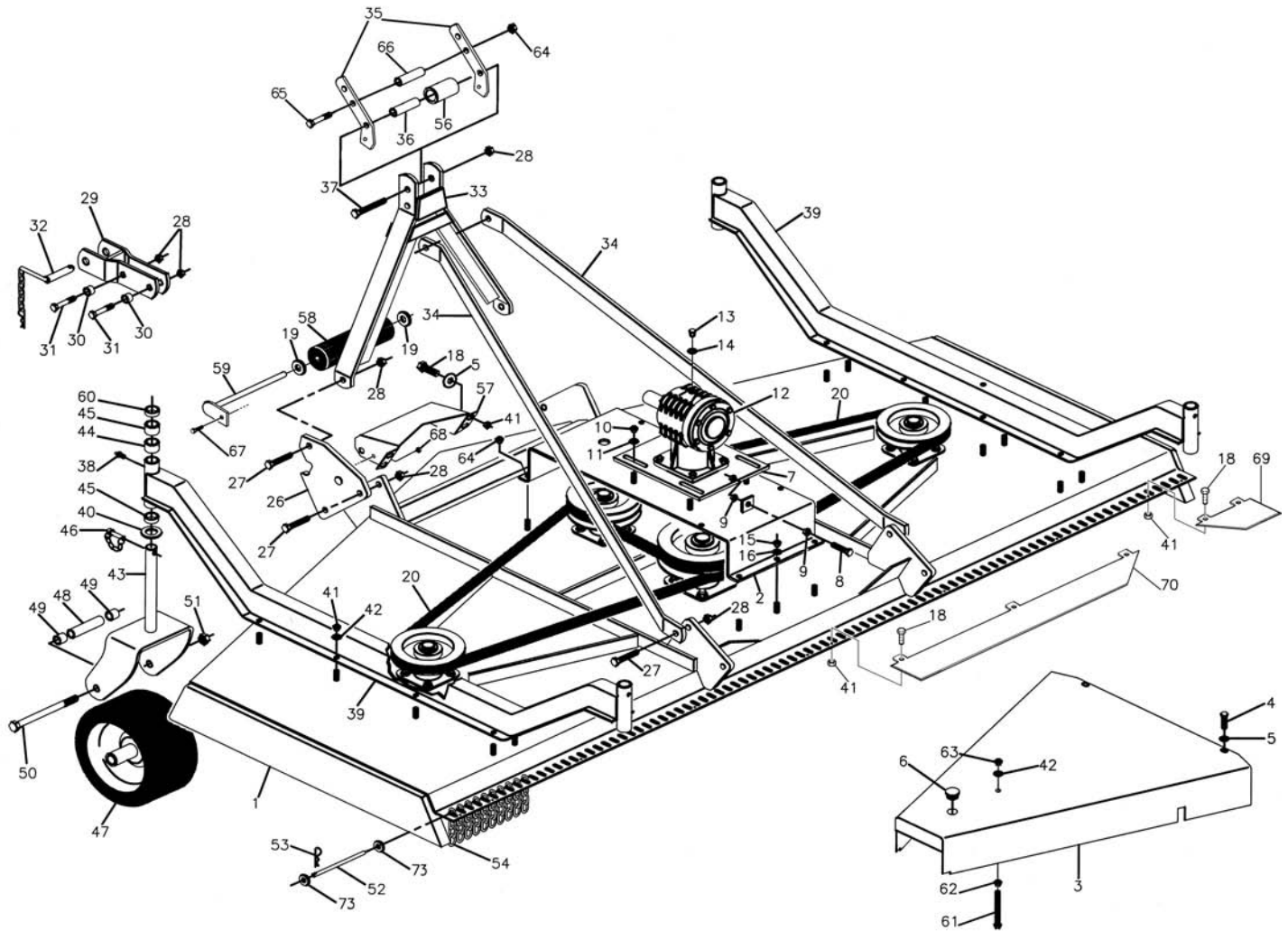

Ref.	Part #	Description	Qty.
36	008-5057	Spacer; First version only	1
	000-6829	Spacer; Ver. A only	1
	004-4067	Spacer, inner; Ver. B (#231020) & above	1
37	000-6834	Bolt HH M16-2.00x150 C8.8 Z P	1
38	000-1065	Grease fitting M10-1.00	4
39	016-7296	Wheel arm w/center hole 90"; C70-090 First version only	1
	026-7296	Wheel arm w/center hole 110"; C70-110 First version only	1
	016-7291	Wheel arm 90"; C70-090 Ver. A & above	1
	026-7291	Wheel arm 110"; C70-110 Ver. A & above	1
40	000-5524	Washer flat Ø33 Z	4
41	003-0156	Nut PT M10-1.50 C6 TK Z	36
42	003-0157	Washer fender Ø10 Z	18
43	006-7305	Wheel yoke for hard tire	4
	006-7371	Wheel yoke for 13" air tire	4
44	004-4129	Spacer 1"	12
45	004-4130	Spacer ½"	4
46	000-8783	Cotter pin	4
47	004-4131	Wheel hard tire, complete	4
	000-6634A	Bearing 6205 Z, greasable hard tire (not shown)	8
	005-1706	Bearing 6205 2RS, non-greasable hard tire (not shown)	8
	004-4134	Wheel cover, hard tire (not shown)	8
	008-4673	Wheel 13" air tire, complete; Ver. D (#262938) & below ²⁰	4
	002-3929A	Bearing, air tire; Ver. D (#262938) & below (not shown)	8
	002-3930A	Retainer, air tire; Ver. D (#262938) & below (not shown)	8
	006-7402	Wheel 13" air tire, complete; Ver. E (#262939) & above	4
	005-1706	Bearing 6205 2RS, air tire; Ver. E (#262939) & above (not shown)	8
	004-4134	Wheel cover, air tire; Ver. E (#262939) & above (not shown)	8
48	004-4138	Inner wheel spacer, hard tire	4
	006-7377	Inner wheel spacer, 13" air tire; Ver. D (#262938) & below	4
	006-7412	Inner wheel spacer, 13" air tire; Ver. E (#262939) & above	4
49	004-4133	Outer wheel spacer, hard tire	8
	006-7414	Outer wheel spacer, 13" air tire; Ver. E (#262939) & above	8
50	004-4135	Bolt HH M14-2.00x170 C8.8 Z P, hard tire	4
	002-3911	Bolt HH M20-2.50x230 C8.8 Z P, air tire	4
51	003-0358	Nut PT M14-2.00 C6 Z TK, hard tire	4
	000-5507	Nut PT M20-2.50 C6 TK Z, air tire	4
52	016-7333	Chain rod 90"; C70-090	1
	026-7333	Chain rod 110"; C70-110	1
53	004-4156	Cotter pin Ø4x25	1
54	004-4158	Chain	-
56	000-6558	Spacer, outer	1
57	000-9622	Support, front roller; Ver. E (#269782) & below	1
	006-7354	Support, front roller; Ver. F (#269783) & above	1
58	006-7358	Front roller Ø3"	1
59	006-7363	Roller pin; Ver. E (#269782) & below	1
	006-7365	Roller pin; Ver. F (#269783) & above	1
60	006-7311	Spacer ¼"	8
61	006-7064	Bolt HH M10-1.50x150 C8.8 Z F	2

²⁰ Wheel no longer available, part #006-7402 should be ordered instead. Ver. D (serial #262938) and below must also order two (2) outer wheel spacers (006-7414) and one (1) inner wheel spacer (006-7412) when replacing wheel.

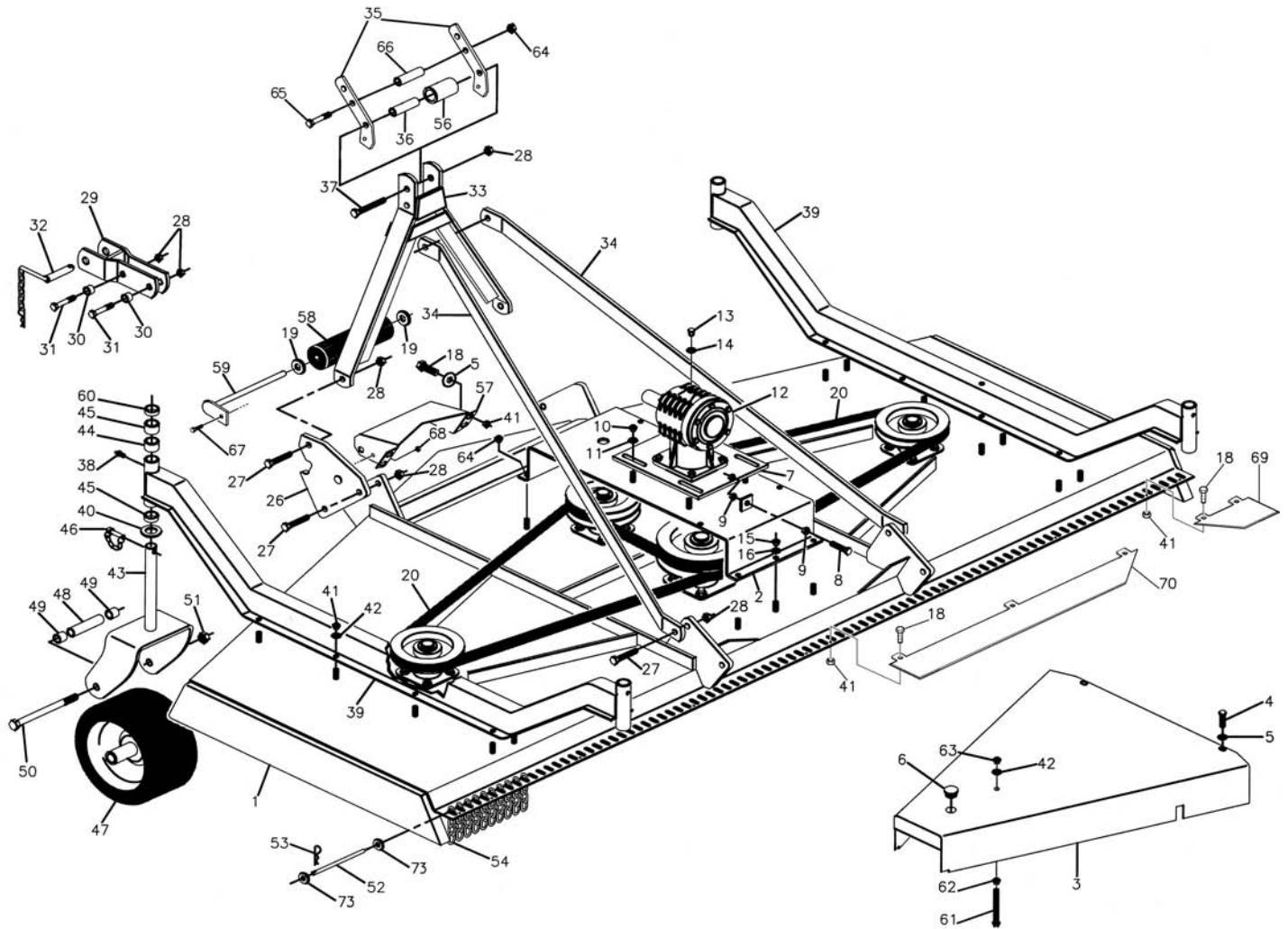

Ref.	Part #	Description	Qty.
62	001-4106	Nut ES M10-1.50 Z TK	2
63	001-5237	Nut ES M10-1.50 Z TN	2
64	003-0064	Nut PT M12-1.75 C6 Z TK	4
65	001-5122	Bolt HH M12-1.75x90 C8.8 Z P	1
66	006-7286	Spacer	1
67	004-6454	Bolt HH M08-1.25x16 C8.8 Z F	1
68	001-1328	Nut PT M08-1.25 C6 Z TK	1
69	006-7385	Rear protection, side 90"; C70-090	2
	006-7388	Rear protection, side 110"; C70-110	2
70	006-7384	Rear protection, center 90"; C70-090	2
	006-7387	Rear protection, center 110"; C70-110	2
73	000-2265	Washer flat Ø12 Z	2
	950-109B	Decal "DANGER - Avoid injury from PTO"	1
	950-111B	Decal "CAUTION - To avoid serious injury"	1
	950-818B	Decal "DANGER - Rotating blades; Thrown objects"	2
	950-406B	Decal "WARNING - Falling off"	1
	950-407B	Decal "WARNING - Crushing and pinching hazard"	1
	950-366B	Decal, red reflective	2
	950-405B	Decal, yellow reflective	1
	950-107B	Decal "BEFCO" medium	1
	950-298B	Decal "Cyclone" small	2
	950-274B	Decal "090"	1
	950-275B	Decal "110"	1
	950-273B	Decal "C70"	1
	950-381B	Decal "BEFCO INC" address	1
	971-138B	Operator's & Parts Manual "Cyclone C70"	1

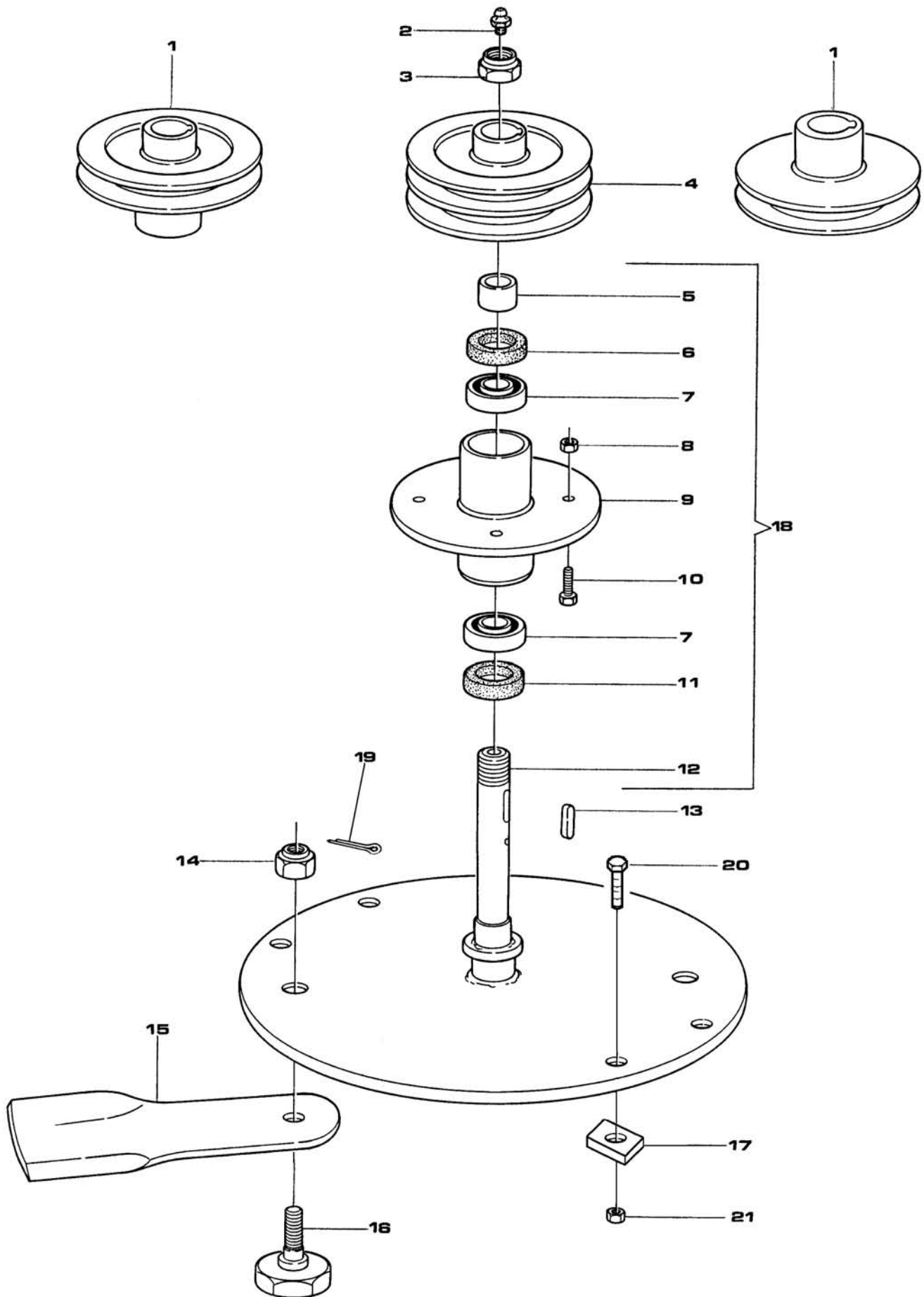

Ref.	Part #	Description	Qty.
1	004-4270	Pulley C/200 x1; Ver. A (#231019) & below ²¹	2
	006-7174	Pulley C/180 x1; Ver. B (#231020) & above	2
2	002-9036	Grease fitting Ø8, press in	3
3	003-7098	Locking ring ES GUK M35-1.50	3
4	004-4269	Pulley C/200x2; Ver. A (#231019) & below ²²	1
	006-7173	Pulley C/180x2; Ver. B (#231020) & above	1
5	006-7185	Spacer	3
6	000-1059	Oil seal 45.65.10	3
7	004-4281A	Bearing 32007	6
8	003-0064	Nut PT M12-1.75 C6 TK Z	12
9	004-4285	Spindle	3
10	002-3265	Bolt HH M12-1.75x40 C8.8 Z F	12
11	006-7191	Oil seal 42.65.10	3
12	006-7202	Spindle rotor	3
13	006-7183	Key 8x10x35	3
14	006-7214	Nut CA M18-2.50 C5 Z TK	6
15	004-4318	Blade 090; C70-090	6
	004-4598	Blade 110; C70-110	6
16	006-7212	Bolt blade SP M18-2.50x48	6
17	004-4317	Blade stop plate	6
18	006-7207	Spindle assembly	3
19	005-7158	Cotter pin Ø4x45	6
20	003-0054	Bolt HH M12-1.75x50 C8.8 Z F; #327518 & below	6
	007-7055	Bolt SP M12-1.25x45 C12.9 Z P; #327519 & above	6
21	003-0064	Nut PT M12-1.75 C6 TK Z; #327518 & below	6
	002-1105	Nut PT M12-1.25 C6 Z; #327519 & above	6

²¹ Pulley no longer available customer should replace with two (2) pulley #006-7174, one (1) pulley #006-7173, two (2) belts #006-7169 for C70-090 or two (2) belts #006-7170 for C70-110.

²² Pulley no longer available customer should replace with two (2) pulley #006-7174, one (1) pulley #006-7173, two (2) belts #006-7169 for C70-090 or two (2) belts #006-7170 for C70-110.

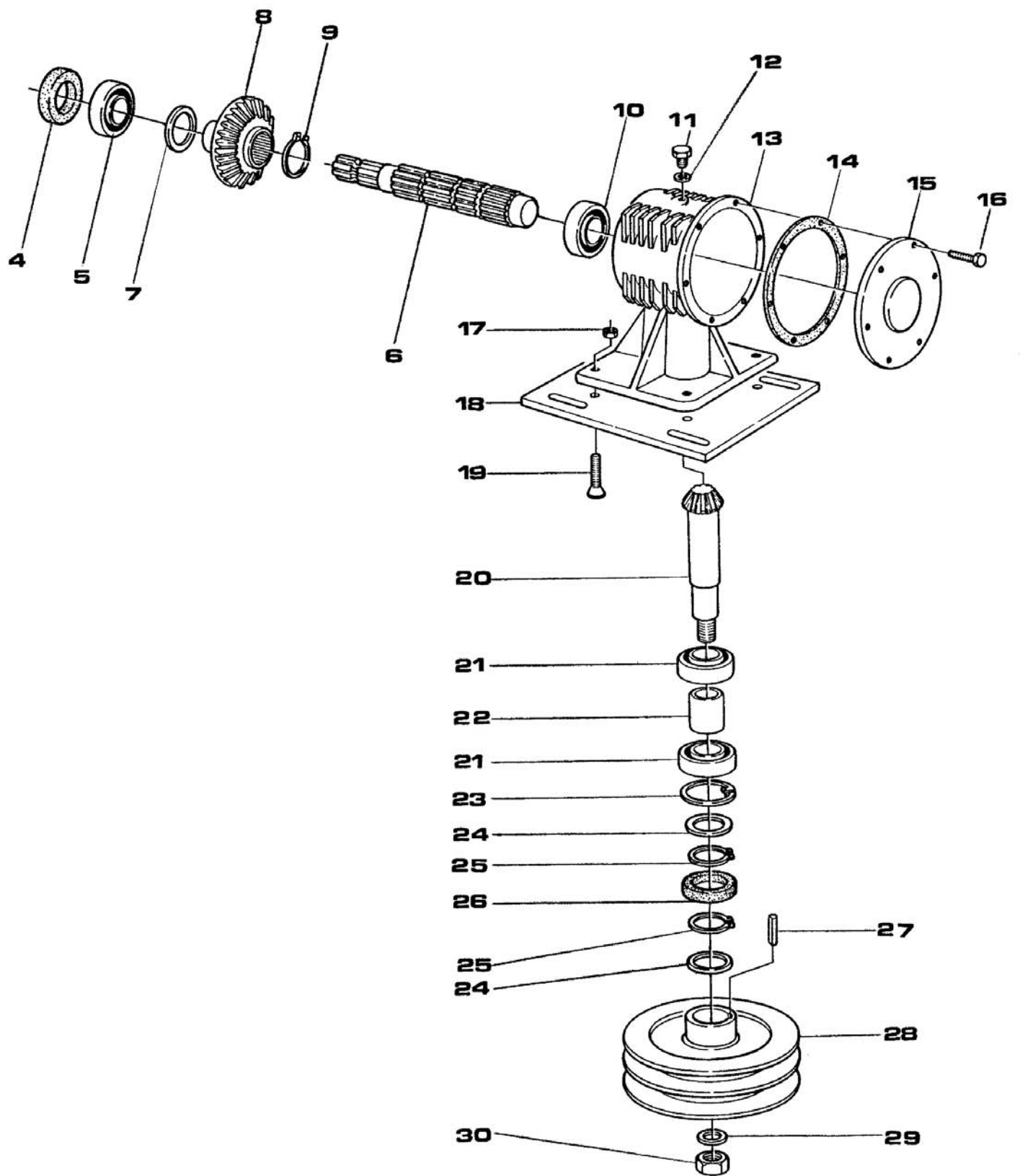

Ref.	Part #	Description	Qty.
4	000-2295	Oil seal 35.62.10	1
5	000-7172A	Bearing 30207	1
6	000-5556	Input shaft	1
7	004-4223	Shim Ø35x45x2	1
8	004-4221	Ring gear	1
9	004-2122	Snap ring, outer Ø35	1
10	004-4217	Bearing 30305	1
11	000-1107A	Breather cap	1
12	000-6691	Gasket	1
13	000-6658	Housing, gearbox	1
14	003-0193	Gasket 2/10	-
	013-0193	Gasket 5/10	-
15	000-6656	Cover, gearbox housing	1
16	000-6349	Bolt HH M10-1.50x20 C8.8 Z F	6
17	003-0064	Nut PT M12-1.75 C6 TK Z	4
18	004-4187	Support plate, gearbox	1
19	007-4183	Bolt CS M12-1.75x40 C10.9 Z F	4
20	004-4222	Pinion gear	1
21	001-2149A	Bearing 6208	2
22	000-6687	Spacer	1
23	000-1154	Snap ring, inner Ø80	1
24	005-3248	Shim Ø40x50x2	2
25	000-8138	Snap ring, outer Ø40	2
26	000-6684	Oil seal 40.80.10	1
27	004-4244	Key 8x7x40	1
28	004-4251	Pulley C/280x2; C70-090	1
	004-4593	Pulley C/250x2; C70-110	1
29	006-6039	Washer flat Ø31 N	1
30	003-0095	Locking ring ES GUK M30-1.50	1
	050-0614	Gearbox 540 rpm, complete ²³	-

²³ Fill using approx. 44 fl.oz. (1.4 qt.) of SAE 90W gear oil.

Ref.	Part #	Description	Qty.
1	1024010C	PTO yoke	2
2	1004020C	Cross w/bearing	2
3	1944070NC	Outer tube w/yoke	1
4	1954072NC	Inner tube w/yoke	1
5	1784210C	Locking ring, outer tube; #269887 & below	1
6	1784201C	Rigid cone, outer tube; #269887 & below	1
7	1784203C	Standard cone (tractor end); #269887 & below	1
8	1784212C	Pin; #269887 & below	2
9	1006065C	Chain, anti-rotation	2
10	1773068C	Shield, outer tube	1
11	1872068C	Shield, inner tube	1
12	1784205C	Long cone (implement end); #269887 & below	1
13	1213233C	Stiffening ring; #269887 & below	2
14	1784202C	Rigid cone, inner tube; #269887 & below	1
15	1784211C	Locking ring, inner tube; #269887 & below	1
16	90SL4068C	Shield, complete ²⁴	1
17	950-463B	Decal "DANGER - Rotating driveline, keep away" outer shield	1
18	950-464B	Decal "DANGER - Guard missing, do not operate" outer tube	1
	050-0416	Driveline, complete	-

²⁴ Complete shielding interchangeable with part #96SL4068C. Single shield components are not interchangeable.

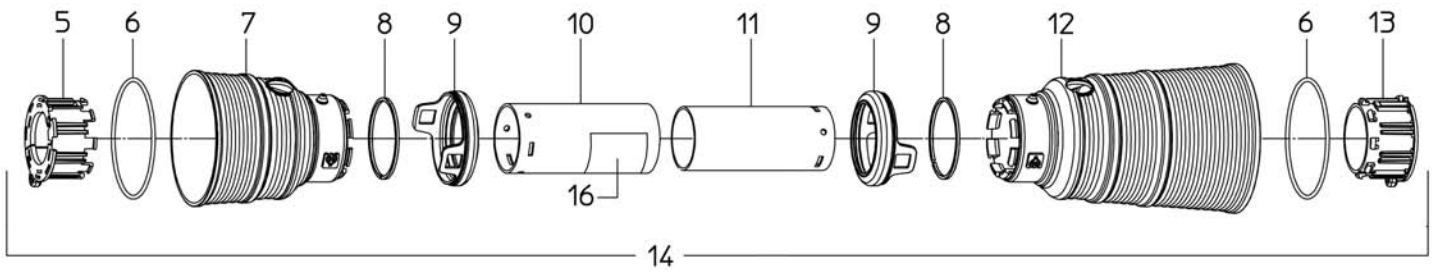
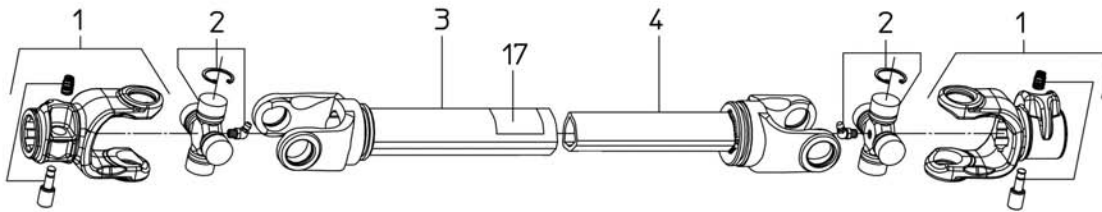

Ref.	Part #	Description	Qty.
1	1024010C	PTO yoke	2
2	1004020C	Cross w/bearing	2
3	1944070NC	Outer tube w/yoke	1
4	1954072NC	Inner tube w/yoke	1
5	1784710C	Locking ring, outer tube; #269888 & above	1
6	1211733C	Stiffening ring; #269888 & above	2
7	1781703C	Standard cone (tractor end); #269888 & above	1
8	1211735C	Safety ring; #269888 & above	2
9	1881709C	Safety sleeve; #269888 & above	2
10	1773068C	Shield, outer tube	1
11	1872068C	Shield, inner tube	1
12	1781704C	Long cone (implement end); #269888 & above	1
13	1784711C	Locking ring, inner tube; #269888 & above	1
14	96SL4068C	Shield, complete	1
15	1006065C	Chain, anti-rotation	2
16	950-463B	Decal "DANGER - Rotating driveline, keep away" outer shield	1
17	950-464B	Decal "DANGER - Guard missing, do not operate" outer tube	1
	050-0416	Driveline, complete	-

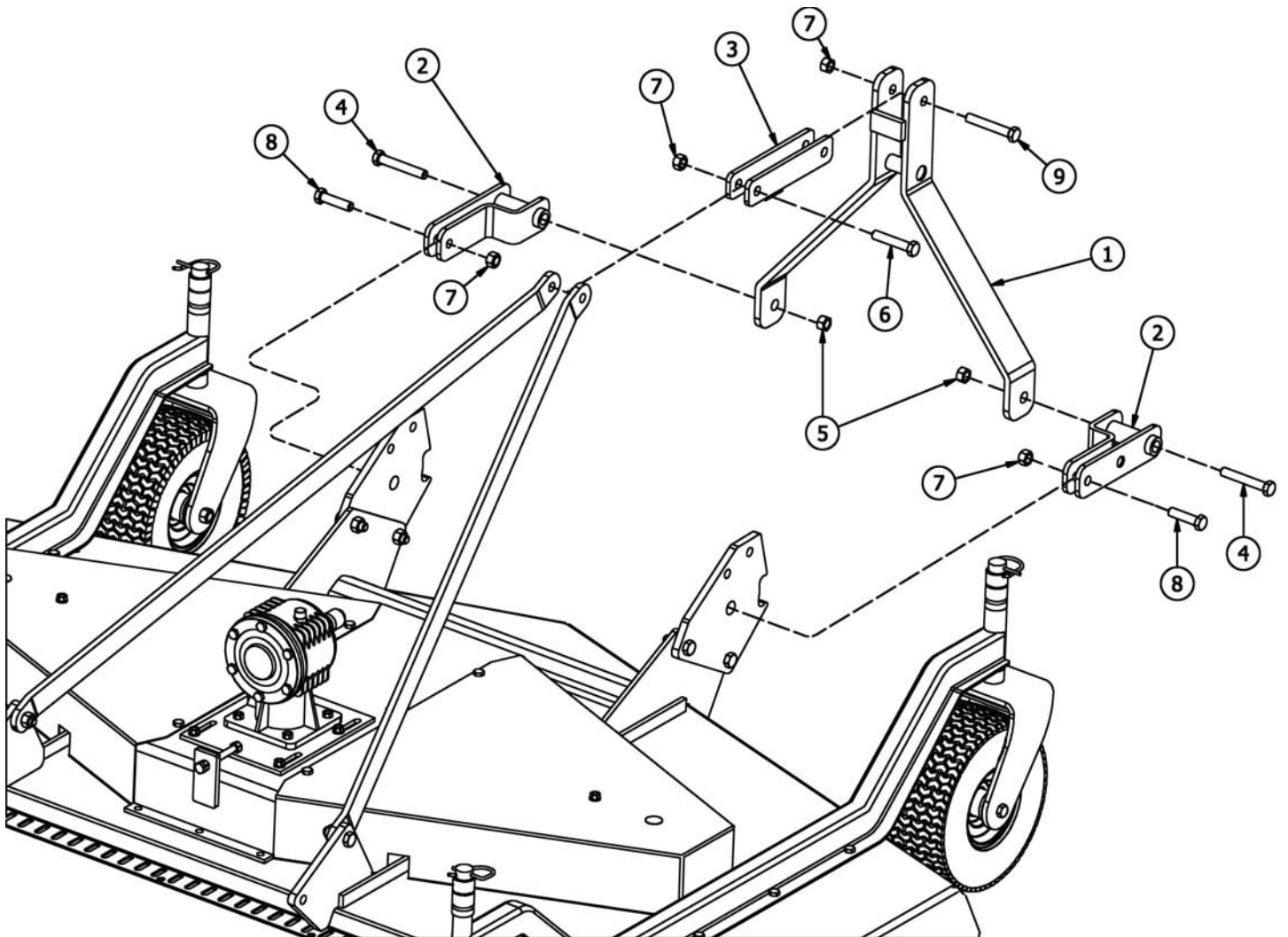

Ref.	Part #	Description	Qty.
1	503-816B	A frame support	1
2	503-815B	Floating yoke	2
3	503-817B	Floating top link	1
4	503-300B	Bolt HH M20-2.50x160 C8.8 Z P	2
5	000-5507	Nut PT M20-2.50 C6 Z TK	2
6	000-6566	Bolt HH M16-2.00x100 C8.8 Z P	1
7	000-5581	Nut PT M16-2.00 C6 Z TK	4
8	000-9884	Bolt HH M16-2.00x65 C8.8 Z F	2
9	007-0346	Bolt HH M16-2.00x110 C8.8 Z P	1
	002-800	Quick Hitch Adapter complete (field conversion kit)	1
	971-214B	Operator's & Parts Manual Quick hitch adapter C50, C70	1

Use only original spare parts

All rights reserved. It is unlawful to copy, reprint or use any of the information or details in this manual without the expressed written permission of the Company. Technical information provided in this manual is approximate, the Company reserves the right to modify or improve the models shown for technical or commercial purposes. Pictures in this manual do not necessarily show the machine as delivered.

BEFCO[®]

P.O. Box 6036
Rocky Mount, NC 27802-6036
Tel.: 252.977.9920 - Fax: 252.977.9718
www.befco.com

